

BSR/HFES 100-2026

Human Factors Engineering of Computer Workstations



Published by the Human Factors and Ergonomics Society
2001 K Street NW, Third Floor North, Washington, DC 20006
info@hfes.org, <http://hfes.org>

© 2026 by the Human Factors and Ergonomics Society. All rights reserved. No portion of this document may be reproduced, stored, or transmitted by any means without prior written permission of the Human Factors and Ergonomics Society. Address orders and permission requests to the Communications Department at the address above.

Table of Contents

Foreword

Chapter 1 Scope

- 1.0 General scope
- 1.1 Conformance

Chapter 2 Cited Standards

Chapter 3 Input Devices

- 3.0 Specifications for input devices
- 3.1 Purpose and scope
- 3.2 Design specifications
 - 3.2.1 General specifications
 - 3.2.2 Intentional movements
 - 3.2.3 Grip surface
 - 3.2.4 Handedness
 - 3.2.4.1 Hand dominance
 - 3.2.4.2 Hand anthropometry
 - 3.2.5 Surface reflectance
 - 3.2.6 Edges, corners, and surfaces
 - 3.2.7 Button placement
 - 3.2.8 Button force and displacement
 - 3.2.9 Button feedback
 - 3.2.10 Button lock
 - 3.2.11 Labels
 - 3.2.12 Control dynamics
- 3.3 Keyboards
 - 3.3.1 Keyboard rows
 - 3.3.2 Keyboard layout
 - 3.3.2.1 Alphabetic keys
 - 3.3.2.2 Numeric keypads
 - 3.3.3 Cursor control
 - 3.3.4 Keyboard height, slope, and wrist/palm support
 - 3.3.5 Profile
 - 3.3.5.1 Dual-state keys
 - 3.3.6 Key nomenclature
 - 3.3.7 Key spacing
 - 3.3.8 Key size and shape
 - 3.3.9 Key rollover/simultaneous key depression

- 3.3.10 Keying feedback
- 3.3.11 Key repeat rate
- 3.3.12 Home row locator
- 3.4 Keyboard wrist/palm rest
- 3.5 Mice
 - 3.5.1 Shape and size
 - 3.5.2 Motion sensor
- 3.6 Trackballs
 - 3.6.1 Diameter
 - 3.6.2 Resistance
- 3.7 Joysticks
 - 3.7.1 Handle size
 - 3.7.2 Force
 - 3.7.3 Displacement
- 3.8 Tablets
 - 3.8.1 Surface
- 3.9 Styli
 - 3.9.1 Surface
 - 3.9.2 Button shape
 - 3.9.3 Diameter
 - 3.9.4 Length
- 3.10 Touchpads
- 3.11 Touch-sensitive panels (touchscreen)
- 3.12 Minimum touch area
 - 3.12.1 Dead space
- 3.13 Target tracking
- 3.14 Metrics
 - 3.14.1 Device stability
 - 3.14.2 Numeric keypad layout
 - 3.14.3 Cursor control
 - 3.14.4 Keyboard height and slope
 - 3.14.5 Key spacing
 - 3.14.6 Key force
 - 3.14.7 Key displacement
 - 3.14.8 Keying feedback
 - 3.14.9 Shape and size
- References

Chapter 4 Electronic Displays

- 4.0 Viewing characteristics
- 4.1 Design viewing distance
- 4.2 Display viewing distance

- 4.3 Multiple displays
 - 4.4 Viewing angle
 - 4.5 Display tilt angle
 - 4.6 Spatial characteristics
 - 4.6.1 Pixel grid modulation, fill factor, and pixel pitch
 - 4.6.2 Pixel and subpixel faults
 - 4.7 Temporal quality
 - 4.7.1 Response time
 - 4.7.2 Flicker
 - 4.7.3 Direct and indirect flicker
 - 4.8 Color and luminance
 - 4.8.1 Luminance range
 - 4.8.2 Luminance nonuniformity
 - 4.8.3 Luminance contrast and reflections
 - 4.8.4 Color uniformity
 - 4.9 Information format
 - 4.9.1 Character height
 - 4.9.2 Character width-to-height ratio
 - 4.9.3 Stroke width
 - 4.9.4 Spacing between characters
 - 4.9.5 Spacing between words
 - 4.9.6 Spacing between lines
 - 4.10 Compliance
- References

Chapter 5 Workstation Furniture

- 5.0 Purpose and scope
- 5.1 Introduction
- 5.2 Anthropometry
 - 5.2.1 Virtual Fit Test Tool
- 5.3 Conformance
 - 5.3.1 Dimensional specifications for workstation components
- 5.4 Postures and acceptable ranges
 - 5.4.1 Whole-body postures
 - 5.4.2 User postures
- 5.5 Installation and configuration of computer workstations
- 5.6 Dimensional measurements
- 5.7 Adjustment controls in the workstation
- 5.8 Pinch points
- 5.9 Radii of edges
- 5.10 Device cabling
- 5.11 Clothing and movement allowances

- 5.12 Work surfaces
 - 5.12.1 Definitions for work surfaces
 - 5.12.1.1 Support surfaces
 - 5.12.1.2 Adjustable surfaces
- 5.13 Primary work surface
- 5.14 Work Zones
- 5.15 User clearances under the work surface
 - 5.15.1 Seated clearances
 - 5.15.2 Standing clearances
- 5.16 Electronic display support
- 5.17 Input device support surfaces
 - 5.17.1 General specifications for sit, stand, or sit/stand input device support surfaces
 - 5.17.2 Sit-only working postures
 - 5.17.3 Stand-only working postures
 - 5.17.4 Sit/stand working postures
 - 5.17.5 Stand-biased workstations
- 5.18 Display support device
 - 5.18.1 Display viewing angle
- 5.19 Seating
 - 5.19.1 Seat height
 - 5.19.2 Seat pan depth and front edge
 - 5.19.3 Seat pan width
 - 5.19.4 Seat pan tilt angle
 - 5.19.5 Seat pan–backrest angle
 - 5.19.6 Backrest height and width
 - 5.19.7 Armrests
 - 5.19.8 Casters
 - 5.19.9 Seating dimensional measurements
- 5.20 Accessories
 - 5.20.1 Document holders
 - 5.20.2 Forearm supports
 - 5.20.3 Footrests
- 5.21 Definitions and guidance of support devices for use with standing-height workstations.
 - 5.21.1 Lean support
 - 5.21.2 Prop
 - 5.21.3 Perch
 - 5.21.4 Stool

References

List of Figures

- 3-1. Row references for conventional keyboards
- 3-2. Numeric keypad layouts

- 3-3. Cursor key layouts
- 3-4. Illustration of keyboard slope. The slope angle " α ," is positive when the A row is lower than the E row, and negative when the A row is higher than the E row. HH = horizontal reference plane, PP = keyboard slope plane, α = slope angle, A = bottom keyboard row, E = number row
- 3-5. Reference wrist 30 degrees extension and 30 degrees flexion
- 3-6. Keyboard height measured from the table surface to middle of home row of keyboard. From ISO 9241, part 4 (ISO, 1998). Keyboard height (1) is measured from the horizontal plane (2)
- 3-7. Keyboard slant (split) (A) and (B), negative tilt (C), and gable (D)
- 3-8. Illustration of key spacing
- 3-9. Illustration of an optical sensor mouse
- 3-10. Illustration of a trackball
- 3-11. Exposed surface and diameter of trackball
- 3-12. Hand-operated (left) and finger-operated (right) joysticks
- 3-13. Illustration of stylus and tablet
- 3-14. Touch panel dead space
- 4-1. Viewing angles
- 4-2. Dimensions of characters
- 4-3. Spacing between characters, lines, and words
- 5-1. Whole-body reference postures for computer workstation users
- 5-2. Acceptable range of elbow angles
- 5-3. Acceptable range of shoulder abduction angles
- 5-4. Acceptable range of shoulder flexion angles
- 5-5. Acceptable range of wrist flexion and extension angles
- 5-6. Acceptable range of torso-to-thigh angles
- 5-7. Recommended primary, secondary, and tertiary (outside the secondary) horizontal workzones
- 5-8. Illustration of a side view of the clearance space. The left side faces toward the user
- 5-9. Plan view of the recommended space for placement for input devices

FOREWORD

This standard contains hardware design specifications that are based on accepted human factors engineering research and experience for computer workstations, their associated furniture, and the end user's workplace environment. This standard was developed by the Human Factors and Ergonomics Society (HFES), using the rules and procedures of the American National Standards Institute (ANSI).

This edition is the first revision of BSR/HFES100-2026, *American National Standard for Human Factors Engineering of Visual Display Terminal Workstations*. This edition of the standard incorporates several extensions based on technological advancements and increased human factors knowledge to the technical areas discussed in ANSI/HFES100-1988.

The members of the ANSI/HFES 100 Committee who drafted this edition are listed below.

Mark E. Benden, PhD, CPE, FHFES
Chair
Texas A&M University

Amrita S. Maguire, MS, AUXP, UXC, FHFES
Cochair 2020–2023
Dell Technologies

Thomas J. Albin, PhD, CPE, PE, FHFES
High Plains Engineering LLC

Scott Openshaw, PhD, CPE
Cochair 2020–2023
Intuitive Surgical

Marvin Dainoff, PhD, FHFES
Marvin Dainoff, LLC

Sumner Adams
A;K Design, LLC

Teresa Bellinger, PhD, CPE
Haworth

Dennis Ankrum
Nova Office Furniture

Carolyn BenseI, FHFES
U.S. Army Research, Development and Engineering
Command

Glenn Azevedo
Danaher Corporation

Theodore Braun, MBA
Keene State College

Ruthjean Banks
California State Compensation Insurance Fund

Jim Briggs, PhD (deceased)
Boeing Commercial Airplane

Dennis Bechis, PhD
National Information Display Laboratory

Dennis Burnside
U.S. Air Force Research Laboratory

Dick Cappels
Apple Computer, Inc.

Matt J. Camilleri
UC Berkeley Ergonomics Program

David Carson
Xybix

David Cochran, PhD, CPE, FHFES
University of Nebraska, Lincoln

H. Harvey Cohen, PhD, CPE, FHFES
Error Analysis, Inc.

Ed Coleman
Lexmark International

John Cone
IBM

Jack Dennerlein, PhD, FHFES
Boston University

Dan Donohoo, PhD
Battelle

Bill Dowell
Herman Miller

Richard Driscoll
BIFMA

George English
KeyTronic

Lauren Gant, PhD, CPE
HNI Workplace Furnishings

James Gerne
Gerner & Associates

Claire Gordon, PhD
U.S. Army Natick Research and Development Center

Chris Grant, PhD
University of Michigan

James Greeson
Ergonomic Solutions

Stephen Guttman
S. H. Guttman Consulting, LLC

Thomas Hayosh
Unisys Corporation

Alan Hedge, PhD, CPE, FHFES
Chair, Environment Subcommittee
Cornell University

Robert Henness
Chair, Visual Displays Subcommittee
Monterey Technologies

Mark Hoffman, MA, CPE
NCR

Meg Honan, MS, CPE
UC Berkeley Center for Occupational & Environmental Health

Carlo Infante, PhD
CBI Technology Consultants

Philip Jacobs, MS, CPE
Jacobs Consulting

Tamara James
Duke University Medical Center

Peter Johnson, PhD
University of Washington

Al Jorgenson
Quantum Data

Edward F. Kelley
NIST

Peter Kennedy
Apple Computer, Inc.

Walter Kleeman, Jr. (deceased)
The Worldport Corporation

Doug Kokot
Koala Consulting

Karl H. E. Kroemer, PhD, FHFES
Virginia Tech

Frank C. Lacson
Imagine Believe Realize

Nancy Larson, PhD, CPE, FHFES
3M

Charlie Lawrence
Workrite Ergonomics

David LeGrande
Communication Workers of America

Win Lochridge
Metamorphosis

LTC Mary Lopez
United States Army

Rani Lueder, MS
Humanics

Rammohan Maikala, PhD, ASP, FHFES
National Safety Council

Walter Makous, PhD
Chair, Visual Displays Canvass Subcommittee
University of Rochester

Richard Marklin, PhD
Marquette University

Daniel McCrobie, PhD
Honeywell, Inc.

Dennis McIntosh
Center for Office Technology

Hugh McLoone
Microsoft

Gerry McVey, PhD (deceased)
Boston University

Sharon Middendorf
Noncommittee Member-Contributor
3M

Ken Miller
Photo Research

Michael Miller, PhD
Eastman Kodak Center

Abbas Moallem
San Jose State University

Dan Odell, PhD, CPE, FHFES
Amazon Lab 126

Michael O'Neill, PhD
Herman Miller

Gary Orr, MSIE, CPE
Department of Labor

Karen Piegorsch
Synergo

Richard Pekelney
RS Pekelney Engineering

Alan Poston
Federal Aviation Administration

Douglas Prickett
Kimball International

Cynthia Purvis Roe
Hewlett Packard Corporation

James Reger, PhD (deceased)
Compaq Computers

Kathleen Robinette, PhD, FHFES
U.S. Air Force Research Laboratory

Michelle M. Robertson, PhD, CPE, FHFES
Office Ergonomics Research Committee
UC Berkeley Center for Occupational & Environmental Health

Marie Robinson
Pacific Bell

Diana Roose, MA
Oberlin College

Fred Schott
Aetna Life and Casualty

Brian Shaw
The Aerospace Corporation

James Sheedy, PhD
Vision Performance Institute, Pacific University

Louis Silverstein, PhD
VCD Sciences, Inc.

Tom Sluchak
IBM

Wanda Smith
Chair, Input Devices Subcommittee
Global Ergonomic Technologies

Kelsey Smithart, DO
University of Colorado Health

Carolyn M. Sommerich, PhD, CPE, FHFES
North Carolina State University

Carla Springer, PhD
C. J. Springer & Associates

Laura Stock
Labor and Occupational Health Program

David Thompson, PhD
Portola Associates

Kathy Uyeda, PhD
TDS Health Care

Harold Welch
Apple Computer, Inc.

Don Williams, PhD
Abilene Christian University

Helmut Zwahlen, PhD, FHFES
Ohio University

Chapter 1 Scope

1.0 General scope

This standard specifies requirements and recommendations for users and for the design and purchase of articles—such as input devices, electronic displays, and furniture—that will be used while working with computers in a fixed, desktop environment. Although this standard does not directly address the use or design of mobile devices, the requirements and recommendations herein might be helpful in designing, using, and purchasing such equipment.

1.1 Conformance

The standard contains two classes of specifications: requirements and recommendations. Requirements are identified by a “**shall**,” whereas recommendations are indicated by a “**should**.”

The requirements and recommendations represent a consolidation and application to practice of the human factors engineering principles for the design and configuration of computer workstations and their components. The requirements and recommendations have been developed from accepted human factors and ergonomics research and established professional practices.

Conformance with this standard can be achieved at either the component level or the system level. “Component conformance” applies to specific devices used in computer workstations. This compliance level is intended to enable manufacturers of workstation components to meet the objectives of the standard apart from considerations involving the configuration of the installed computer workstation.

Evaluations of product conformance with this standard are intended to be performed by professionals who are familiar with and trained in the procedures and measurement techniques involved. To encourage consistency and comparability across conformance evaluations, assessment protocols are presented in each chapter.

Although a workstation and its individual components may comply with the standard when initially configured, the conformance requirements are intended to apply throughout the life cycle of a computer workstation. Systems integrators and evaluators should review installed workstations whenever components are added, modified, replaced, or removed.

NOTE: All normative dimensions in this standard are given in SI units (e.g., meters, kilograms, seconds). Dimensions given in U.S. customary units such as inches and pounds are presented for advisory purposes only and are nonnormative.

Chapter 2 Cited Standards

ANSI/BIFMA X5.1, General Purpose Office Chairs—Tests

ANSI/BIFMA X5.3, Vertical Files—Tests

ANSI/BIFMA X5.5, Desk Products—Tests

ANSI/BIFMA X5.9, Lateral Files—Tests

BIFMA CMD-1-2013 Universal Measurement Procedure for the Use of BIFMA Chair Measuring Device

BIFMA G1 – 2013 Ergonomics Guideline

IEC 62341-6-1: Organic light-emitting diode (OLED) displays—Part 6-1. Measuring methods of optical and electro-optical parameters

Information Display Measurements Standard (ICDM), International Committee for Display Metrology (2012)

ISO 24496:2021 Office furniture – Office chairs – Methods for the determination of dimensions

ISO 9241-303:2011 – Ergonomics of human-system interaction – Part 303: Requirements for electronic visual displays

ISO 9241-307: Ergonomics of human-system interaction—Part 307: Analysis and compliance test methods for electronic visual displays

Society for Information Display Information Display Measurement Standard (Version 1.03) (2012)

Chapter 3 Input Devices

3.0 Specifications for input devices

This chapter presents design specifications for alphanumeric keyboards and selected non-keyboard input devices used in computer workstations. These specifications, along with those in Chapter 5, Furniture, are intended for designers and manufacturers of input devices.

3.1 Purpose and scope

The purpose of this chapter is to establish minimum design specifications for selected technologies used as primary and auxiliary user input devices at computer workstations in office settings. The scope of this chapter pertains to design features of alphanumeric keyboards, selected cursor control devices, and direct-touch input devices as listed below.

- Keyboards
- Mouse devices
- Trackballs
- Joysticks
- Styli
- Indirect (touch) input devices
- Direct-touch input devices

The specifications presented in this chapter are intended to apply to devices used for producing, editing, and using text and graphics presented on computer visual displays.

3.2 Design specifications

3.2.1 General specifications

The following specifications apply to all input devices considered in this chapter and intended for an adult user population. Designers and manufacturers of specific input devices are referred to these general specifications and to the relevant specifications in Chapter 5, Furniture.

Input devices placed on a stable horizontal surface **should**

be stable (i.e., not wobble or stick) during normal operation

Likewise, integrated buttons and keys **should**

be stable (i.e., not wobble or stick) during normal operation

Activation of integrated buttons or keys **should not**

cause inadvertent movement of the input device (potentially leading to unintended inputs or errors)

Device instability (from slipping or rocking) and poor grip surfaces can adversely affect performance and lead to increased effort and errors. Smooth key and button action aids performance, reduces keying effort, and promotes user satisfaction. Button activation that requires users to alter their grip frequently can result in increased effort, unintentional cursor movement, and difficulty in simple object (target) acquisition (see Cushman & Rosenberg, 1991, chapters 8 and 13).

3.2.2 Intentional movements

Users **should**

be able to position input devices accurately and quickly without exerting excessive effort or force.

However, the effort or force required to position the input device **should**

be sufficient to prevent the device from unintended drifting or changing of position

The goal is to strike a balance between the effort and force required for the user to position the device easily and the need for the device to remain stable at its intended position.

3.2.3 Grip surface

The grip surfaces **should**

be sized, shaped, and textured to prevent slipping and unintended movements during normal operation

Input devices with buttons **should**

permit button activation without requiring alteration of the hand grip

3.2.4 Handedness

3.2.4.1 Hand dominance

An input device designed for one-handed operation **should**

be operable with either hand

If the input device is designed for operation by a particular hand, then both left- and right-handed versions **should**

be available to users

3.2.4.2 Hand anthropometry

Input devices **should**

accommodate the anthropometry of users; for example, reach and hand size

When reasonable, input device geometry **should**

be adjustable by users to accommodate their anthropometry

3.2.5 Surface reflectance

Specular reflectance of input device surfaces that are visible during normal operation **should**

be 45 percent or less

Excessive reflectance of surfaces visible during normal operation can cause glare, which might lead to user discomfort and degraded visual performance (Sanders & McCormick, 1993, pp. 533–539).

3.2.6 Edges, corners, and surfaces

Hard surface edges and corners that come into contact with the user during normal operation **should**

have a radius of at least 2 mm (0.078 in.)

Radius is defined as the distance from the rounded surface to the center of the circle creating the arc. For surfaces that are not perfectly round or of constant radius, the minimum/smallest radius of the surface should be used. Flush-mounted features are excluded from this recommendation. Prolonged or frequent pressure and contact with sharp edges and corners can lead to discomfort, distraction, and degraded performance.

3.2.7 Button placement

Thumb- and finger-operated buttons on input devices **should**

be accessible during normal operation and **should**

be activated with thumb/finger flexion, not extension

Hard-to-reach input device buttons or those that necessitate awkward or extreme thumb and/or finger motions can lead to fatigue and degraded performance.

3.2.8 Button force and displacement

For tasks involving frequent use of buttons on an input device, the maximum force needed to press and activate such buttons **shall**

be between 0.25 N and 1.5 N (0.9 ounce-force and 5.4 ounce-force)

Buttons **should**

have a displacement between 1.0 mm and 6.0 mm (0.04 in. and 0.24 in.)

Buttons **should**

support the resting weight of the thumb/finger in order to minimize accidental activation or the need to suspend the thumb or finger over the button in order to prevent accidental actuation

Although most research on the operation of small push-buttons is associated with keying, typing, and keyboards, it is reasonable to generalize from this research to the use of push buttons on other input devices, especially when tasks involve frequent push-button operation. Consequently, this specification is supported by the literature and general consensus regarding minimum and maximum key activation forces.

3.2.9 Button feedback

Input device buttons **should**

provide feedback to users upon activation

Tactile or auditory feedback modes, or combinations of these feedback modes, are acceptable.

If auditory feedback is provided through software, it **should**

be user-suppressible

A consistent research finding involving keying and push-button use is that feedback is essential during the acquisition of keying skill. Feedback aids in facilitating learning. Tactile feedback is suggested for high-volume or high-frequency button use and keying. Auditory and/or visual feedback as well as tactile feedback can be helpful during training (Cushman & Rosenberg, 1991).

3.2.10 Button lock

A locking feature **should**

be provided for buttons on input devices that are used for tasks involving prolonged or continuous button depression

The button-lock feature is intended to relieve or reduce the necessity for continuous pressure by the finger to activate a button during specific task operations. This specification can be met through hardware or software controls.

3.2.11 Labels

Labels on input device controls **should**

be visually distinguishable and interpretable to users

Text-based labels **should**

be printed in a sans-serif font and in title case (i.e., uppercase first letter and remaining letters in lowercase)

Buttons, keys, and controls with full or partial function labels often lead to better performance than do unlabeled ones. Effective ways to label and group functions include borders, colors, fonts, labels, shape, size, shading, and spatial separation. If text labels are not feasible (e.g., because of space constraints), graphic symbols may be employed.

3.2.12 Control dynamics

The control dynamics, such as control/display ratio, of non-keyboard input devices **should**

be user adjustable, within appropriate limits and, if applicable, to the device and

be compatible with users' expectations for direction, speed, and location of movement through appropriate user references and examples

Control/display ratio (C/D ratio) is the relationship between movements of an input device and the associated movements of a visual indicator on a display screen. A low C/D ratio indicates that small device movements move the visual indicator rapidly across screen distance, whereas a high C/D ratio indicates that large device movements result in slow or small visual indicator movements. A user-adjustable C/D ratio is advantageous for accommodating user proficiency and task demands that require varying degrees of rapid, gross-distance movements and accurate, fine positioning.

3.3 Keyboards

3.3.1 Keyboard rows

Keyboard rows are described by the codes "A," "B," "C," "D," and "E" (see Figure 3-1).

Row A is closest to the user; Row C is the center or home row. Some keyboards do not have a Row E. Additional rows of keys follow this same naming convention; for example, an additional row would be labeled as Row F, and so forth.

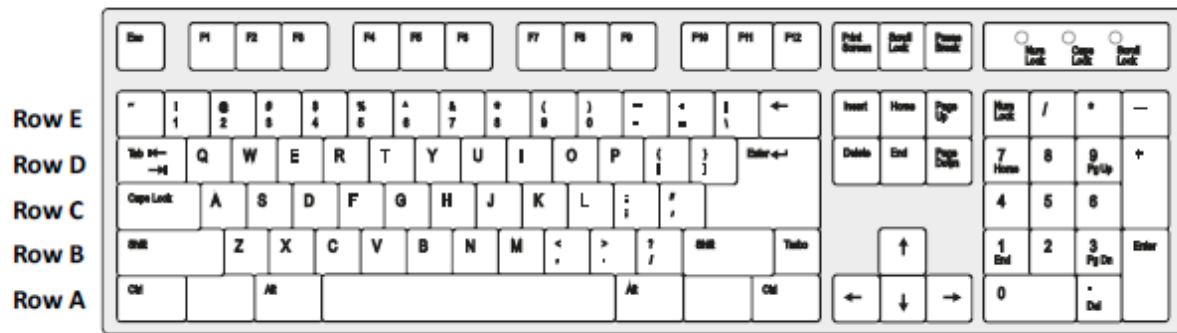

Figure 3-1. Row references for conventional keyboards.

3.3.2 Keyboard layout

3.3.2.1 Alphabetic keys

The alphabetic keys **should**

be grouped in the primary keying area

and function keys (the first row of keys beyond the alphanumeric portion of the keyboards) **should**

be located next to the primary keying area

Key grouping as shown in Figure 3-1 aids the logical organization of keyboards and facilitates the standardization of key layouts (Sanders & McCormick, 1993, p. 457). Standardization of key layouts is important and beneficial for users who need to transfer among computer workstations. Widely different layouts often involve a negative transfer of learning, which can affect performance. In this regard, the QWERTY keyboard layout has been accepted as the de facto industry layout. QWERTY is the sequence of the letters on the left-hand side of the top row of alphabetic keys. However, research exists that supports the acceptability of other keyboard layouts (e.g., the Dvorak keyboard) for general text-entry tasks (Alden, Daniels, & Kanarick, 1972).

3.2.2.2 Numeric keypads

In the design and manufacture of keyboards, numeric keypads **shall**

be provided when users' primary task involves numeric data entry

These keys **shall**

be grouped together

and, if integrated with the keyboard, **should**

be located to the side of the primary keying area

Either of the two numeric keypad layouts in Figure 3-2 is recommended. Keys with similar functions **should** be grouped together

Usability studies on the layout of numeric keypads have supported both the telephone and calculator layouts (Conrad & Hull, 1968; Deininger, 1960; Lutz & Chapanis, 1955; Seibel, 1972).

The location of the keypad on the right-hand side of the primary keying area is conventional industry practice, although this location does not best accommodate left-handed users. Because key positions for the zero, double zero, triple zero, comma, decimal, and other such keys may be application dependent, alternative locations for such keys might influence performance.

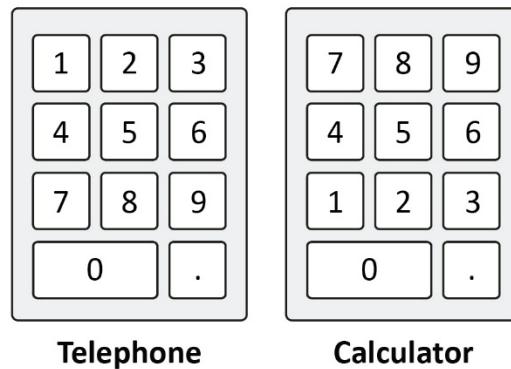

Figure 3-2. Numeric keypad layouts.

3.3.3 Cursor control

A two-dimensional cursor control (e.g., cursor keys, mouse, trackball) **shall**

be provided for text- and graphics-processing tasks

If cursor keys are provided, they **shall**

be arranged in a two-dimensional layout (four examples of possible layouts are illustrated in Figure 3-3)

and they **should**

be dedicated to cursor movement

If the cursor keys have collateral functions, their operational mode status **shall**

be clearly indicated

Additional keys placed near the cursor controls are acceptable provided that the overall layout of the cursor control keys is unchanged. There are two main patterns, the “cross” and the “inverted T.” Each has two variants that differ only by their location in the keyboard rows, as shown in Figure 3-3.

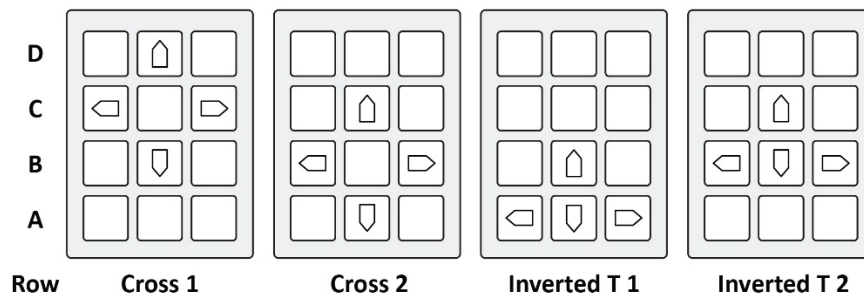

Figure 3-3. Cursor key layouts.

The usability of cursor keys is influenced by users’ expectations for spatial and/or positional compatibility with the direction of cursor movements. Emmons (1984) showed that the performance of inexperienced (novice) users was greater with a cross arrangement than with a box format. Reger, Snyder, and Epps (1987) showed that the inverted T was the most preferred of six common arrangements and that no significant performance or preference differences existed between the inverted-T and cross cursor control arrangements.

Editing keys (PageUP, PageDown) **should**

be provided for keyboard navigation, control, and editing purposes

These keys **should**

be arranged in a functional group

3.3.4 Keyboard height, slope, and wrist/palm support

Keyboards, in combination with their supporting surface, chair, and other furniture, **shall**

permit users to attain the postural design criteria in the selected reference posture stated in Chapter 5, Furniture, 5.4.2, User postures

The goal with keyboard height and slope designs/adjustments is to promote neutral postures in the wrist

and forearm when using the device. Figures 3-4 and 3-6 illustrate keyboard tilt and keyboard height, respectively.

Consistent with these postural design criteria, the slope of conventional keyboards (rectangular keyboards with an alphanumeric and numeric keypad area and on which the home row of keys forms a straight line) **shall**

be between 0 degrees and 15 degrees in its unadjusted position, and **should**

provide at least one positive slope setting between 0 degrees and 15 degrees

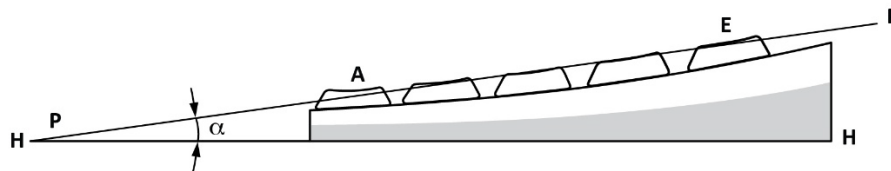

Figure 3-4. Illustration of keyboard slope. The slope angle " α ," is positive when the A row is lower than the E row, and negative when the A row is higher than the E row. HH = horizontal reference plane, PP = keyboard slope plane, α = slope angle, A = bottom keyboard row, E = number row.

For contemporary or alternative keyboard designs that attempt to minimize the deviation of the hand and/or wrist from a neutral posture, in order to promote neutral wrist postures, the keyboard slope may extend beyond the stated positive slope range as well as include negative slopes. The goal is to promote a neutral posture in both the flexion/extension and radial/ulnar planes and with regard to rotation of the forearm (pronation/supination). Generally, neutral flexion/extension of the wrist is described as the position where the horizontal plane created by the back of the hand is even and parallel with the horizontal plane created by the back of the forearm (Figure 3-5).

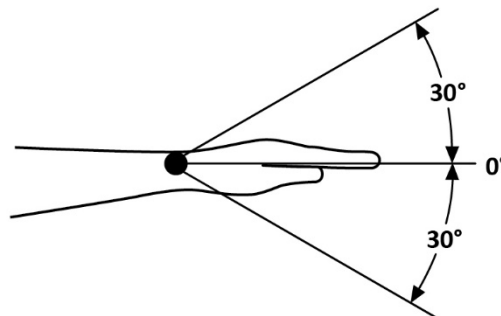

Figure 3-5. Reference wrist 30 degrees extension and 30 degrees flexion.

Keyboard height and slope are interrelated (see Chapter 5). Whereas slope adjustments up to 15 degrees have been incorporated into conventional keyboard designs, research has shown user preferences for even greater slopes (Burke, Muto, & Gutmann, 1984; Emmons & Hirsch, 1982; Miller & Suther, 1981).

Some keyboard designs, as illustrated in Figure 3-7, might use height, articulation, and tilt advantageously to aid in promoting neutral wrist posture (Hedge & Powers, 1995; Simoneau & Marklin, 2001).

If a height and/or slope adjustment mechanism is provided, there **shall**

be at least one adjustment that allows the keyboard to conform to the height specification

The preferred keyboard height is 30 mm (1.2 in.) or less and **should not**

exceed 35 mm (1.37 in.)

Keyboard height is the height measured from the table surface to the middle of the home row of the keyboard.

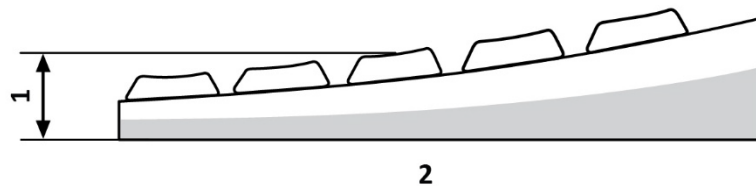

Figure 3-6. Keyboard height measured from the table surface to middle of home row of keyboard. From ISO 9241, part 4 (ISO, 1998). Keyboard height (1) is measured from the horizontal plane (2).

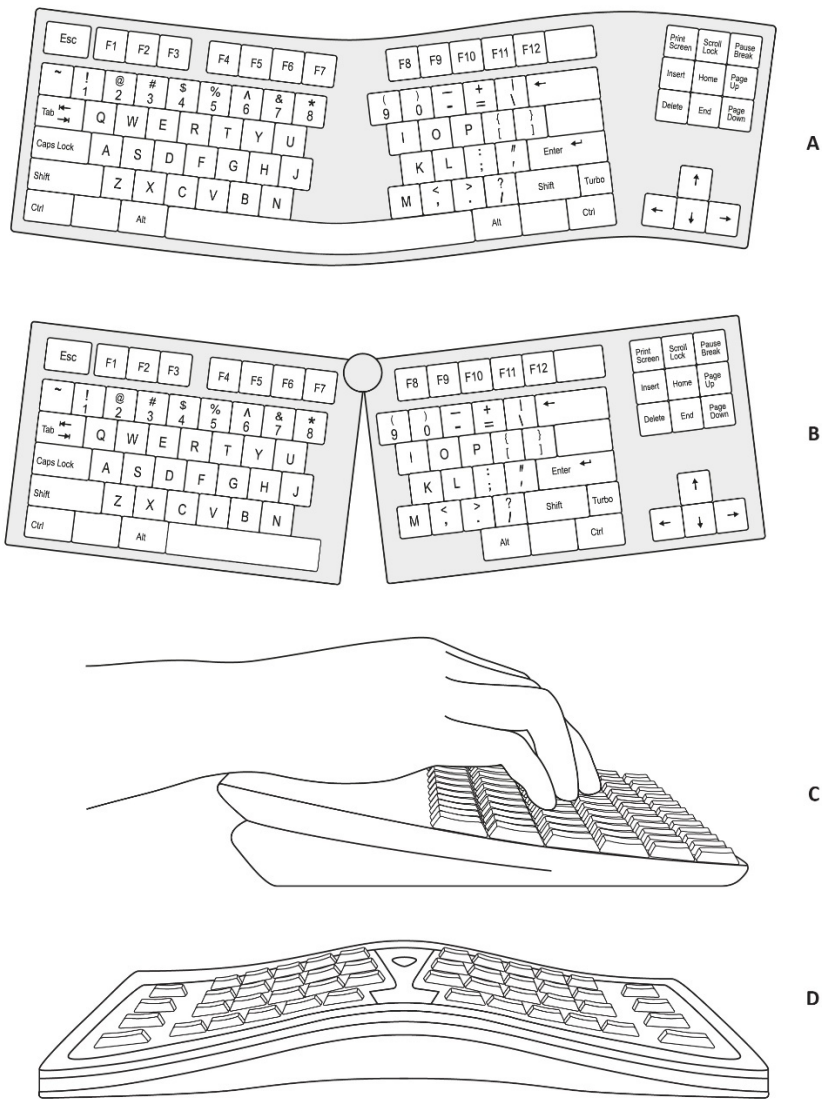

Figure 3-7. Keyboard slant (split) (A) and (B), negative tilt (C), and gable (D)

3.3.5 Profile

The keyboard rows **should**

be arranged in a dished (concave), stepped, sloped, or flat profile

Various keyboard profiles are considered acceptable (Çakir, Hart, & Stewart, 1980, pp. 125–126). Research examining stepped and sloped keyboard profiles found no notable differences in user performance (Kinkead & Gonzales, 1969). Other keyboard profiles might be possible; however, they have not been studied with regard to acceptability.

3.3.5.1 Dual-state keys

Dual-state (toggle) keys **should**

indicate their operational (functional) status

Dual-state keys include keys such as Caps Lock, Num Lock, Scroll Lock, and Function Lock. A common problem with dual-state keys or push-buttons is visual identification of the position or state of the key. An effective solution is to provide a separate indicator light (see Cushman & Rosenberg, 1991, chap. 8). Therefore, the preferred method for the status of dual-state keys is an indicator light.

When indicator lights are employed, they **should**

be embedded in the key, located close to the associated keys or

be clearly labeled if not located close to the keys (e.g., Caps Lock icon)

An indicator panel for one or more dual-state keys is acceptable. Other means for indicating the status of dual-state keys may be used effectively, such as showing the functional status on the receiver of a wireless keyboard or on the primary/main display.

3.3.6 Key nomenclature

Nomenclature for the primary symbols on the alphabetic (i.e., A through Z) keys of the keyboard **shall**

be a minimum of 2.6 mm (0.10 in.) in height and **should**

have a minimum contrast ratio between legend and key background of 3:1

Key nomenclature may be darker or lighter than the background.

The key nomenclature height recommendation is based on text- and display-related legibility research. Legibility is the rapid identification of single characters that may be presented in a non-contextual format. The threshold height for comfortable reading during a legibility task is in the range of 16 minutes to 18 minutes of visual arc (0.267 degrees to 0.3 degrees). A character height of 2.6 mm (0.102 in.) viewed from a distance of 560 mm (22.0 in.) would yield a symbol size of 16 minutes of visual arc.

3.3.7 Key spacing

The centerline-to-centerline horizontal and vertical spacing between adjacent keys within the alphanumeric and numeric zones **shall**

be within a range of 17 mm to 20 mm (0.67 in. to 0.79 in.)

See Periera et al. (2013); Periera, Hsieh, Laroche, and Rempel (2014); and Madison et al. (2015) for discussions of key spacing.

Function keys and infrequently used keys may be smaller. The specification for horizontal and vertical key spacing is supported by conventional practice. The key-spacing specifications apply to keys within a functional group but not to the separation between functional groups of keys, such as noncontiguous keys in a conventional or alternative keyboard design.

As shown in Figure 3-8, key spacing is the distance between corresponding points on two adjacent keys, measured horizontally (S_h) and vertically (S_v).

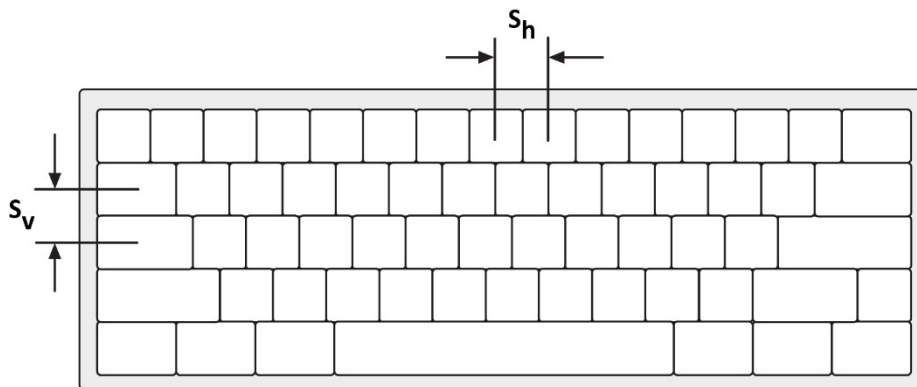

Figure 3-8. Illustration of key spacing.

3.3.8 Key size and shape

For alphabetic keys in the alphabetic key area, the horizontal strike surface **should**

be at least 12 mm (0.47 in.) wide and the contact surface **should**

be concave to match the geometry of the tip of the finger and enhance coupling during the strike

Rectangular (square) strike surfaces on keys provide larger target areas than do circular strike surfaces for a given key spacing. Also, concave keys provide a good fit to fingertips (Çakir et al., 1980; Clare, 1976).

3.3.9 Key rollover/simultaneous key depression

Key rollover refers to the number of characters produced by simultaneous activation of keys. Keyboards **should**

have at least three-key rollover. An n-key rollover is recommended

Two-key rollover permits a second key to be depressed while one key is already down but will not produce a character until the first key is released. If the second key is released before the first key, the second key will be missed. If two keys are pressed simultaneously, all output is blocked. Three-key rollover will produce two characters accurately for two simultaneously depressed keys. Depression of a third key does not produce a

character until one of the first two keys is released. In contrast, n-key rollover will produce any number of characters accurately no matter how many keystrokes overlap (Greenstein & Muto, 1988). N-key rollover is preferred to two-key and three-key rollover schemes (Davis, 1973; Gladman, 1976; Kallage, 1972).

3.3.10 Keying feedback

Actuation of any key **shall**

be accompanied by tactile or auditory feedback, or both

If auditory feedback is provided, the sound **should**

occur at the same point in the displacement for all keys

If the auditory feedback is provided through software, the user **should**

be able to adjust the volume and turn it off

If tactile feedback is provided, the point of key activation (switch closure or make point) **should**

be marked by a distinguishable breakaway force

Tactile feedback for the key activation (snap point) can be implemented by increasing key force throughout the initial 40 percent of key displacement, then reducing key force over the next 20 percent of total displacement where the switch closure occurs, and again increasing key force over the remaining key displacement range.

Feedback is essential during the acquisition of keying skills; however, detailed specifications are difficult to establish because feedback effectiveness depends on feedback mode, user keying skill, task demands, and keyboard layout. Elimination of the breakaway force or the subsequent cushioning force can result in slower keying activity, higher error rates, and increased operator fatigue (see Cushman & Rosenberg, 1991, chap. 8; Kinkead & Gonzales, 1969; Klemmer, 1971).

3.3.11 Key repeat rate

The default character repeat rate **should**

be approximately 10 characters per second after an initial delay of 500 ms following key activation

The character repeat rate **should**

be user adjustable

Key repeat allows the user to enter a character or command multiple times without needing to repeat keystrokes. Most conventional keyboards implement the key repeat function on all keys. The keyboard repeat

rate may be implemented in either the hardware or the software.

3.3.12 Home row locator

The home row keys (Row “C” as in Figure 3-1) **should**

contain at least one tactile feature per hand to assist users in positioning their fingers on the keyboard

Current industry practice is to use a small raised bar, a dimple, or some other shape on the key cap. A tactile indicator on the home row keys, typically the F and J keys in the alphanumeric area and the number 5 key on the numeric keypad, provides a reference landmark for users to orient their hands and fingers over the home row and the keyboard (Gladman, 1976, p. 149). A tactile indicator on the number 5 key in the numeric keypad also can be used as a reference landmark for users to orient their hands and fingers over the numeric keypad.

3.4 Keyboard wrist/palm rest

The intent of a wrist rest is to promote more neutral postures in the wrist. For keyboards with integrated or attachable wrist rests/palm supports for the proximal portion of the palm, the rests or supports **shall**

avoid contact with sharp corners on the keyboard or wrist rest

be matched to, or higher than, the width, height, and shape of the front edge and slope of the keyboard

Sharp corners and/or small radius edges that create pressure points should be avoided. Matching the width, height, and shape of the rest or supports to the front edge of the keyboard provides a smooth transition from the surface of the rest or support surface to that of the keyboard. Differences in width, height, and shape between the rest or support and the keyboard might be cumbersome, constrain the user, or limit access to the keyboard. Some users prefer to use wrist rests with keyboards. However, some rests might inhibit motion of the wrist during typing. Thus, a wrist rest is considered an optional feature.

3.5 Mice

A mouse (Figure 3-9) is a hand-operated input device typically used for two-dimensional cursor-positioning and object-selecting tasks. The mouse often resembles a palm-sized, contoured block with one or more thumb- and/or finger-operated buttons. The mouse is moved over a surface in order to move a cursor on the screen.

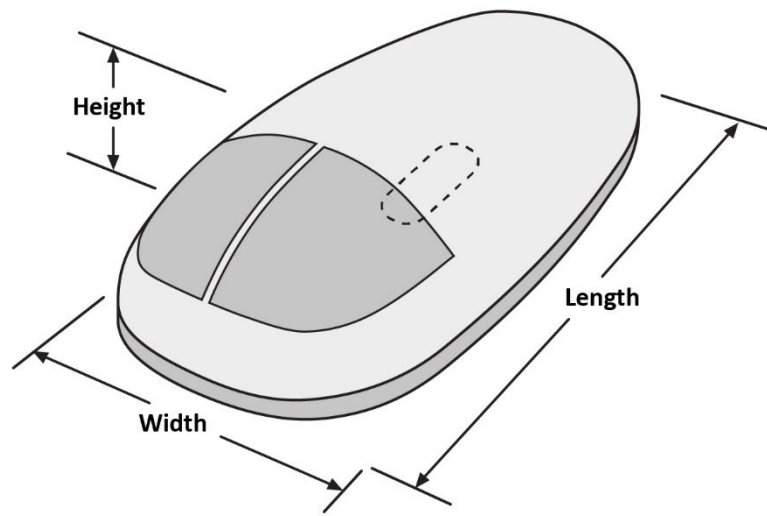

Figure 3-9. Illustration of an optical sensor mouse.

3.5.1 Shape and size

The shape and size of a mouse **shall**

allow single-handed operation

Users can comfortably grip rectangular-shaped mice that are between 40 mm and 70 mm wide (1.6 in. and 2.8 in.), between 70 mm and 120 mm long (2.8 in. and 4.7 in.) , and between 25 mm and 40 mm high (0.9 in. and 1.6 in.) (Goy, 1988; U.S. Department of Defense, 1989). Overly form-fitting mouse designs should be avoided because they can result in continual and prolonged contact between the device and the skin's surface, reducing the ability of the skin to breathe and resulting in hand perspiration. Overly form-fitting mouse designs offered in just one size rarely work well for a wide variety of hand sizes.

3.5.2 Motion sensor

The motion sensor **should**

be located toward the front of the input device, under the fingertips, not the palm

This specification is intended to facilitate fine-positioning accuracy with the device through greater sensitivity in fingertip-driven and/or wrist-based movements. Locating the rolling ball or motion sensor underneath the fingertips increases the apparent moment of inertia as the device is pivoted from the elbow or the heel of the hand (Verplank & Oliver, 1989). This assists hand movements involved in fine positioning because the forward location conveys the motion of the hand more accurately.

3.6 Trackballs

A trackball (Figure 3-10) is a hand-operated or finger-operated input device that is used typically for cursor movement and object selection tasks. Trackballs generally are mounted into a horizontal surface (desk or

keyboard) or are built into their own module. These devices can include finger-operated and thumb-operated buttons located near the ball. Users' rotations of the trackball cause movements of the cursor on the screen. Trackballs can be rotated in any direction to generate any combination of x and y control.

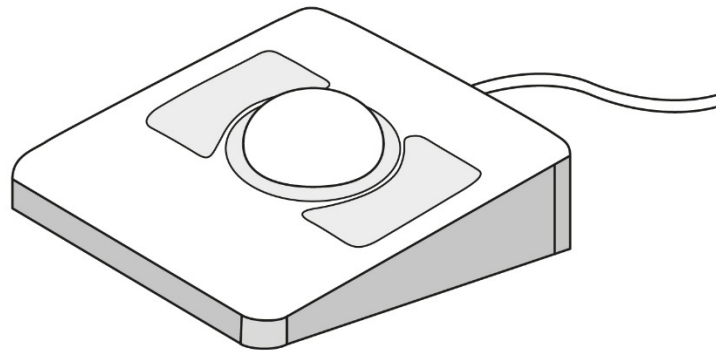

Figure 3-10. Illustration of a trackball.

3.6.1 Diameter

As shown in Figure 3-11, the diameter of a desktop-mounted trackball **should**

be between 50 mm and 150 mm (1.97 in. and 5.9 in.)

The exposed surface of the trackball **should**

be between 100 degrees and 140 degrees

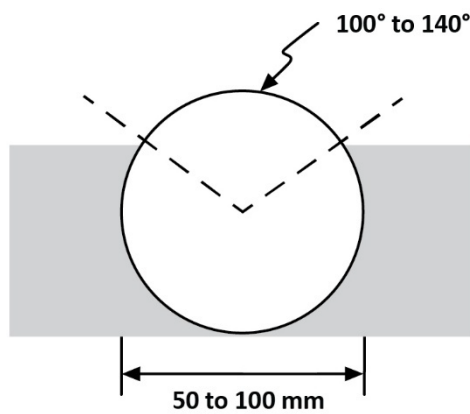

Figure 3-11. Exposed surface and diameter of trackball.

This specification is based on conventional practice (U.S. Department of Defense, 1989). Task-related factors to consider when selecting an appropriate trackball include types of motions and cursor movements, level of precision required, and space constraints.

3.6.2 Resistance

Resistance **should**

be less than 1.0 N (0.22 pounds force) and preferably less than 0.3 N (0.66 pounds force)

This specification is based on conventional practice (U.S. Department of Defense, 1989). It is intended to enable users to apply a minimum amount of force to move the trackball accurately. Some amount of resistance is necessary to dampen the ball.

3.7 Joysticks

A joystick (Figure 3-12) is a finger- or hand-operated device used for two-dimensional tracking tasks and complex perceptual/motor tasks. It also may be used for pointing and selection tasks, if precision is not critical. Joysticks consist of a handle for the main control interface, and these devices may contain one or more buttons on the handle top or device housing (Arnaut & Greenstein, 1988, p. 101; Cushman & Rosenberg, 1991, p. 196).

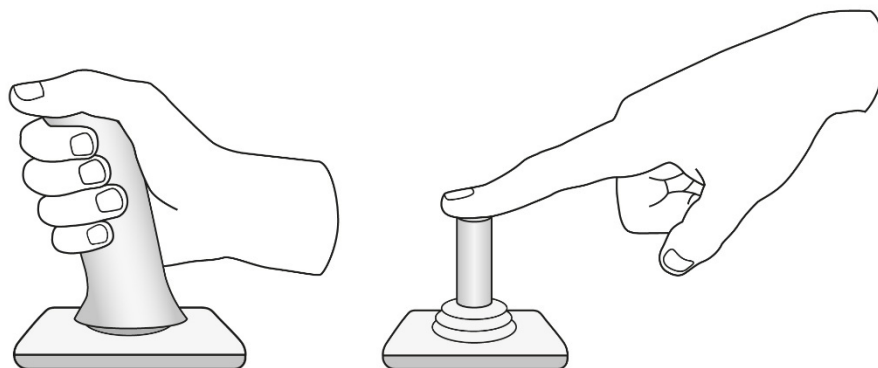

Figure 3-12. Hand-operated (left) and finger-operated (right) joysticks.

3.7.1 Handle Size

The grip surface of a hand-operated joystick **should**

be less than 50 mm (1.97 in.) in diameter and

be 110 mm to 180 mm (4.3 in. to 7.1 in.) long

The handle of a finger-operated joystick **should**

be between 6.5 mm and 16.0 mm (0.26 in. and 0.63 in.) in diameter and

be between 25 mm and 150 mm (0.98 in. and 5.9 in.) long

The handle size specifications are based on basic anthropometric considerations and conventional practice (Arnaut & Greenstein, 1988; U.S. Department of Defense, 1989).

3.7.2 Force

The force to displace the cursor with a hand- or finger-operated joystick **should**

be at least 4.5 N (1.01 pound force)

A force (isometric) joystick responds to pressure on the joystick to move the cursor or visual indicator. For joysticks with a handle diameter of between 9 mm and 10 mm, a full-scale force of approximately 9.0 N to 15.0 N tends to work best for graphics tasks. A minimum force of 4.5 N is recommended (Doran, 1989).

3.7.3 Displacement

For displacement (isotonic) joysticks, the angular displacement from the rest position **should not**

exceed 45 degrees

The angular displacement specification is based on conventional practice (U.S. Department of Defense, 1989). Angular displacements beyond 45 degrees require a greater range of motion and involve more demanding hand and wrist postures.

3.8 Tablets

Tablets (Figure 3-13) are flat, slate-like panels that can be used for cursor movement and object selection tasks. Typically, a tablet is configured with a stylus to provide the user with an electronic digitizing surface. Many tablet systems consist of opaque overlays, which provide graphics used for the cursor movement and for button activation.

3.8.1 Surface

The active area of a tablet or touch-sensitive surface **should**

be flat, smooth, and free from warping or surface imperfections

Uneven surfaces and surface abnormalities can create an unstable work situation, interfering with an input device and the user's finger. Such conditions can lead to an increase in errors, effort, and fatigue.

3.9 Styli

Styli (Figure 3-13) are handheld input devices used for object selection, cursor movement, and freehand drawing tasks. They have a pencil-like shape and may contain one or more finger-operated buttons. Typically,

styli are used with a tablet-like device (e.g., tablet computer, visual display, or pressure-sensitive tablets).

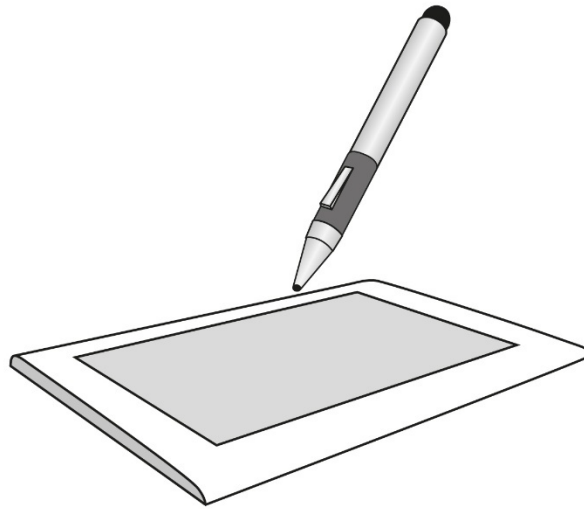

Figure 3-13. Illustration of stylus and tablet.

3.9.1 Surface

The exterior surface of the stylus **should**

be slip resistant

The exterior grip surface of a stylus is a key design component in the stability and effort involved during its use. A stylus that is comfortable to hold and easy to grip will aid in an operator's effectiveness.

3.9.2 Button shape

Barrel-mounted buttons on a stylus **should**

be shaped for comfort and not cause excessive pressure points

Barrel-mounted buttons or switches on a stylus are typically used to make selections or provide additional functionality. Button or switch designs that have sharp edges or corners or create an excessive pressure point can rapidly lead to discomfort or distraction and can potentially degrade performance.

3.9.3 Diameter

The diameter of a stylus **should**

be between 7.0 mm and 20.0 mm (0.28 in. and 0.79 in.)

The barrel size of the stylus can affect the operator's comfort, grip, and overall effectiveness. This specification is based on conventional practice and is intended to enable the user to comfortably grip the barrel of

the stylus (U.S. Department of Defense, 1989).

3.9.4 Length

The length of a stylus **should**

be between 120 mm and 180 mm (4.7 in. and 7.1 in.)

The length and balance of a stylus can affect the operator's effectiveness. This specification is based on basic anthropometric considerations and conventional practice. It is intended to provide users with an adequate stylus length to improve overall effectiveness (U.S. Department of Defense, 1989).

3.10 Touchpads

Touchpads are small, touch-sensitive tablets typically found in notebook computers. These devices implement indirect touch, in which the finger is located remotely from the visual display. They typically use relative motion mapping for cursor control. Some touchpads can operate with an absolute positional mapping (for handwriting input or drawing). Gestures or special areas of the touchpad usually can be used to initiate specific responses (e.g., scrolling and window selection), and touchpad sizes have increased to accommodate these gestures. Increased touchpad size also is associated with better performance in pointing tasks, in both decreased movement time and frequency of clutching, with pointing performance plateauing with a touchpad size of about 178 mm × 100 mm (7.0 in. and 3.9 in.) (Camilleri, Chu, Ramesh, Odell, & Rempel, 2012). Conversely, larger touchpads mounted below keyboards (such as those typically found in notebook computers) increase the risk of inadvertent actuation of the touchpad by the palms while typing. Algorithms to reject this type of unintended input are recommended. These are usually based on reducing sensitivity based on touch location (especially the top corners of the touchpad), rejecting touch input during active typing, and recognizing the size and shape of the touch inputs.

Note that these algorithms should be tested in conjunction with the full input set, including all gestures, to ensure that desired inputs are not filtered out. However, because touchpads are used primarily for single-finger pointing, greater weight should be afforded to ensuring pointing performance over multi-finger gesture performance. Conversely, because false tap selections by the palm can cause profound issues (e.g., unintentional pointer insertions, text deletions, and button selections), a conservative approach for tap selections is recommended (e.g., a default setting to disable tap selection), and controls to customize the tap gesture (e.g., contact location [within the region described by pointing], duration, and force).

Touchpads typically enable selection (similar to left and right mouse buttons) in one of three ways: by tapping on the pad with one or multiple fingers, through physical buttons adjacent to the touchpad, or by making the full surface of the touchpad function as a clickable button (through either physical switches or haptic feedback). Activation forces for touchpads with fully clickable surfaces are generally recommended to be in the 100- to 150-gram-force range to balance ease of activation while avoiding inadvertent clicking while performing normal pointing or gesture inputs on the surface. Surfaces of touchpads should provide low friction for easy interaction and low abrasion for finger comfort.

3.11 Touch-sensitive panels (touchscreens)

Touch-sensitive panels enable direct manipulation of digital on-screen objects by integrating a touch sensor into a display. People interact with touchscreens via one or more fingers performing direct touch and/or gestures, or via an input device, such as a stylus, which can provide more precision and additional affordances. Touchscreens can offer benefits for more intuitive interaction, but they also create new challenges, such as occlusion of visual elements as the hands work over the display, and different requirements, as users now touch displays that previously they only looked at.

Workstation touchscreens require balancing the competing interests of the visual and musculoskeletal systems, as the screen must be easily touched as well as seen. Touchscreen studies demonstrate that preferred distances tend to be closer, and preferred angles tend to be lower, compared with non-touchscreens, to reduce the shoulder loads associated with touch (Shin & Zhu, 2012; Camilleri, Malige, Fujimoto, & Rempel, 2013). Recommended viewing angles for the center of touchscreens are from 35 degrees to 45 degrees below the horizontal, with viewing distances close to the minimum as recommended with non-touchscreens (400 mm or 15.7 in.).

3.12 Minimum touch area

The optimum touch-sensitive area for a soft key depends on the application and required accuracy. Smaller soft keys afford greater key density but require greater accuracy and, thus, greater acquisition time for similar error rates. Touch targets are generally recommended to be 9 mm × 9 mm or greater for accuracy, with targets down to 7 mm × 7 mm being acceptable for functions in which accuracy is less important.

When accuracy is important, touch areas (soft keys) **should**

be at least 9 mm (0.35 in.) wide and 9 mm (0.35 in.) high

For uses when accuracy is less important, touch areas **should**

be at least 7 mm (0.28 in.) wide by 7 mm (0.28 in.) high

3.12.1 Dead space

The dead space surrounding each touch area **should**

be at least 3.2 mm (0.13 in.)

Dead spaces (see Figure 3-14) minimize accidental activation of keys, especially when parallax is present or when touch areas are small (Beringer & Peterson, 1985; Martin, 1988; Usher & Ilett, 1986). Smaller dimensions for the dead space can be used when error-preventing algorithms are used to encode the touch-area activations.

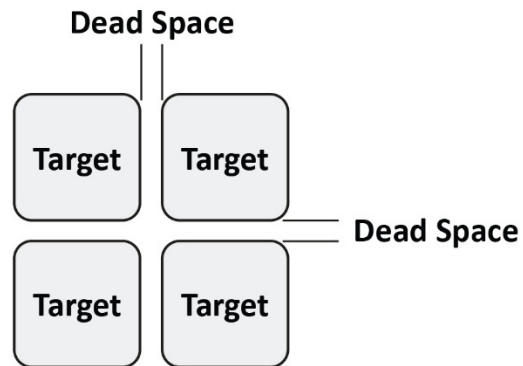

Figure 3-14. Touch panel dead space.

3.13 Target tracking

During a select-and-drag operation, the object or cursor being moved **should**

track the finger, both temporally and spatially

Real-time tracking provides the user with direct feedback on target status and position. Latency is more critical for direct than for indirect input, with just-noticeable differences for dragging and tapping tasks of 40 ms for direct input and 75 ms for indirect input (Deber, Jota, Forlines, & Wigdor, 2015).

3.14 Metrics

3.14.1 Device stability

Observe the input device during normal, expected use. Determine whether or not it slips or rocks during use. The input device should be installed as per design instructions.

To assess the stability of input device keys, observe the input device in normal, expected use. Determine whether or not the keys wobble or stick.

3.14.2 Numeric keypad layout

Determine if a numeric keypad is provided as appropriate for users. Verify that the keys on the numeric keypad are arranged in one of the patterns shown in Figure 3-2.

3.14.3 Cursor control

Determine whether a two-dimensional cursor control is provided for users, as is appropriate. If cursor control keys are provided, verify that the keys are arranged in one of the two patterns shown in Figure 3-3.

3.14.4 Keyboard height and slope

Verify that the keyboard, when installed as directed, does not cause the user to violate the postural guidelines described in Chapter 5, section 5.4.2. Verify that the slope of the keyboard is between 0 degrees and

15 degrees. The slope of the keyboard is determined by the angle between the plane of the support surface and the plane passing through the centers of the keys, or other equivalent and corresponding points of keys, in the rows containing Q and Z in the QWERTY layout (Figure 3-4).

3.14.5 Key spacing

Vertical and horizontal key spacing is measured from key centers as shown in Figure 3-8.

3.14.6 Key force

Key force is the maximum force necessary to the snap point measured in the geometric center of the keytop strike area along the same axis as the key travel.

3.14.7 Key displacement

Key displacement is measured in the axis of the key travel.

3.14.8 Keying feedback

Verify by observation that key actuation is accompanied by either tactile or auditory feedback.

3.14.9 Shape and size

Verify by observation that the mouse can be operated with one hand.

References

- Alden, D. G., Daniels, R., & Kanarick, A. F. (1972). Keyboard design and operation: A review of the major issues. *Human Factors*, *14*, 275–293.
- Armstrong, T. J., Foulke, J. A., Martin, B. J., Gerson, J., & Rempel, D. M. (1994). Investigation of applied forces in alphanumeric keyboard work. *American Industrial Hygiene Association Journal*, *55*, 30–35.
- Arnaut, L. Y., & Greenstein, J. S. (1988). Human factors considerations in the design and selection of computer input devices. In S. Sherr (Ed.), *Input devices* (pp. 71–122). Academic.
- Beaton, R. J., & Weiman, N. (1984). *Effects of touch key size and separation on menu-selection accuracy* (Tech. Report TR 500-01). Human Factors Research Laboratory, Tektronix.
- Beringer, D. B., & Peterson, J. G. (1985). Underlying behavior parameters of the operation of touch-input devices: Biases, models, and feedback. *Human Factors*, *27*, 445–458.
- Burke, T. M., Muto, W. H., & Gutmann, J. C. (1984). Effects of keyboard height on typist performance and preference. In *Proceedings of the Human Factors Society 28th Annual Meeting* (pp. 272–276). Human Factors and Ergonomics Society.
- Çakir, A., Hart, D. J., & Stewart, T. F. M. (1980). *Visual display terminals*. Wiley.
- Camilleri, M., Chu, B., Ramesh, A., Odell, D., & Rempel, D. (2012). Indirect touch pointing with desktop computing: Effects of trackpad size and input mapping on performance, posture, discomfort, and preference. In *Proceedings of the Human Factors and Ergonomics Society 56th Annual Meeting* (pp. 1114–1118). Human Factors and Ergonomics Society.
- Camilleri, M. J., Malige, A., Fujimoto, J., & Rempel, D. M. (2013). Touch displays: The effects of palm rejection technology on productivity, comfort, biomechanics and positioning. *Ergonomics*, *56*, 1850–1862.
- Clare, C. R. (1976). Human factors: A most important ingredient in keyboard designs. *EDN*, *21*(8), 99–102.

- Conrad, R., & Hull, A. J. (1968). The preferred layout for numerical data-entry keysets. *Ergonomics*, *11*, 165–173.
- Cushman, W. H., & Rosenberg, D. J. (1991). *Human factors in product design*. Elsevier.
- Davis, S. (1973, March). Keyswitch and keyboard selection for computer peripherals. *Computer Design*, pp. 67–79.
- Deber, J., Jota, R., Forlines, C., & Wigdor, D. (2015, April). How much faster is fast enough?: User perception of latency & latency improvements in direct and indirect touch. In *Proceedings of the 33rd Annual ACM Conference on Human Factors in Computing Systems* (pp. 1827–1836). ACM.
- Deininger, R. L. (1960). Human factors engineering studies of the design and use of pushbutton telephone sets. *Bell Systems Technical Journal*, *39*, 995–1012.
- Doran, D. (1989). Trackballs and joysticks. In S. Sherr (Ed.), *Input devices* (pp. 251–270). Academic.
- Emmons, W. H. (1984). A comparison of cursor-key arrangements (box versus cross) for VDUs. In E. Grandjean (Ed.), *Ergonomics and health in modern offices* (pp. 214–219). Taylor & Francis.
- Emmons, W. H., & Hirsch, R. S. (1982). Thirty-millimeter keyboards: How good are they? In *Proceedings of the Human Factors Society 26th Annual Meeting* (pp. 425–429). Human Factors and Ergonomics Society.
- Gladman, R. (1976). Human factors in the design of visual display units. In D. Grover (Ed.), *Visual display units and their application* (pp. 137–152). IPC Science and Technology.
- Goy, C. (1988). Mice. In S. Sherr (Ed.), *Input devices* (pp. 219–250). Academic.
- Grandjean, E. (1987). Design of VDT workstations. In G. Salvendy (Ed.), *Handbook of human factors* (pp. 1359–1397). Wiley-Interscience.
- Greenstein, J. S., & Arnaut, L. Y. (1987). Human factors aspects of manual computer input devices. In G. Salvendy (Ed.), *Handbook of human factors* (pp. 1450–1489). Wiley-Interscience.
- Greenstein, J. S., & Muto, W. H. (1988). Keyboards. In S. Sherr (Ed.), *Input devices* (pp. 123–178). Academic.
- Hedge, A., & Powers, J. A. (1995). Wrist postures while keyboarding: Effects of a negative slope keyboard system and full motion forearm supports. *Ergonomics*, *38*, 508–517.
- International Organization for Standardization. (ISO). (1998). *ISO 9241-4: Ergonomic requirements for office work with visual display terminals (VDTs)—Part 4: Keyboard requirements*. Author.
- Kallage, R. (1972, February). Electronic keyboard design with n-key rollover. *Computer Design*, pp. 57–61.
- Kinthead, R. D., & Gonzales, B. K. (1969). Human factors design recommendations for touch-operated keyboards (Document 12091-FR). Honeywell.
- Klemmer, E. T. (1971). Keyboard entry. *Applied Ergonomics*, *2*, 2–6.
- Lutz, M. C., & Chapanis, A. (1955). Expected locations of digits and letters on ten-button keysets. *Journal of Applied Psychology*, *39*, 314–317.
- Marklin, R. W., Simoneau, G. G., & Monroe, J. F. (1999). Wrist and forearm posture from typing on split and vertically inclined computer keyboards. *Human Factors*, *41*, 559–569.
- Martin, G. L. (1988). Configuring a numeric keypad for a touch screen. *Ergonomics*, *31*, 945–953.
- Miller, I., & Suther, T. W. (1981). Preferred height and angle settings of CRT and keyboard for a display station input task. In *Proceedings of the Human Factors Society 25th Annual Meeting* (pp. 492–496). Human Factors and Ergonomics Society.
- Pereira, A., Hsieh, C. M., Laroche, C., & Rempel, D. (2014). The effect of keyboard key spacing on typing speed, error, usability, and biomechanics, part 2: Vertical spacing. *Human Factors*, *56*, 752–759.

- Pereira, A., Lee, D. L., Sadeeshkumar, H., Laroche, C., Odell, D., & Rempel, D. (2013). The effect of keyboard key spacing on typing speed, error, usability, and biomechanics: Part 1. *Human Factors*, *55*, 557–566.
- Madison, H., Pereira, A., Korshøj, M., Taylor, L., Barr, A., & Rempel, D. (2015). Mind the gap: The effect of keyboard key gap and pitch on typing speed, accuracy, and usability, part 3. *Human Factors*, *57*, 1188–1194.
- Reger, J. J., Snyder, H. L., & Epps, B. W. (1987). Performance and preference for cursor-key control configurations in editing tasks. *Society for Information Display Digest*, 22–25.
- Sanders, M. S., & McCormick, E. J. (1993). *Human factors in engineering and design*. Wiley.
- Seibel, R. (1972). Data entry devices and procedures. In H. P. Van Cott & R. G. Kinkade (Eds.), *Human engineering guide to equipment design* (pp. 311–348). U.S. Government Printing Office.
- Shin, G., & Zhu, X. (2012). User discomfort, muscle activity, and performance in touch screen interactions. In *Proceedings of the Human Factors and Ergonomics Society 56th Annual Meeting* (pp. 1077–1081). Human Factors and Ergonomics Society.
- Simoneau, G. G., & Marklin, R. W. (2001). Effect of computer keyboard slope and height on wrist extension angle. *Human Factors*, *43*, 287–298.
- U.S. Department of Defense. (1989). *Human engineering design criteria for military systems, equipment and facilities*. Author
- Usher, D. M., & Ilett, C. (1986). Touch-screen techniques: Performance and application in power station control displays. *Displays*, *7*, 59–67.
- Verplank, W., & Oliver, K. (1989). Microsoft mouse: Testing for redesign. In *Proceedings of Interface '89* (pp. 257–261). Human Factors and Ergonomics Society.
- Weisner, S. J. (1988). A touch-only user interface for a medical monitor. In *Proceedings of the Human Factors Society 32nd Annual Meeting* (pp. 435–439). Human Factors and Ergonomics Society.

Chapter 4 Electronic Displays

4.0 Viewing characteristics

4.1 Design viewing distance

The design viewing distance is a viewing distance, specified by the manufacturer, at which all the requirements of this standard can be met.

The minimum design viewing distance **should**

be 40 cm (15.7in.)

4.2 Display viewing distance

The display viewing distance is the distance between the nasal bridge in any reference posture (see Figure 4-1) and the center of the screen image area. The display viewing distances discussed here can be applied to cases of single- and multiple-display configurations. They should not be confused with the *design viewing distance*

Those working with the displays available in 1988–1991 found that viewers considered a 50 cm (19.7in.) distance too close for typical computer workstation tasks (Jaschinski-Kruza, 1988, 1990, 1991) and that greater visual fatigue was associated with a 50 cm (19.7 in.) viewing distance than with a 100 cm (39.4 in.) viewing distance (Jaschinski-Kruza, 1990).

Past work (Jaschinski, Heuer, & Kylian, 1998; Psihogios, Sommerich, Mirka, & Moon, 2001; Sommerich, Joines, & Psihogios, 2001) has shown that most users prefer viewing distances from 75 cm to 83 cm, or 29.5 in. to 32.7 in. (when text size is large enough to meet the 16 arc minutes requirement, discussed in 4.9.1, Character height). Viewing distances closer than a typical viewer’s resting focus—which is usually about 67 cm (26.4 in.) but varies from 29 cm to 192 cm (11.4 in. to 75.6 in.) in the reference population (Andre & Owens, 1999; Leibowitz & Owens, 1978)—require greater effort for accommodation and convergence than do farther distances (Collins, O’Meara, & Scott, 1975; Fisher 1977). This assumes normal or corrected-to-normal vision and an age less than 40 years, because many viewers older than 40 are unable to accommodate to a display 40 cm (15.7 in.) away without eyeglasses or other optical assistance (Charness, Dijkstra, Jastrzembki, Weaver, & Champion, 2008; Turner, 1958).

A display **should**

be positioned between 50 cm (19.7 in.) and 100 cm (39.4 in.) from the eyes

NOTE: This recommendation is for desktop displays. ISO 9241-303 suggests a 30 cm (11.8 in.) design viewing distance, which might be more common for handheld displays on mobile devices.

4.3 Multiple displays

When viewing two or more displays, the distance from the user's eyes to the center of each screen **should**
be equal

The primary display **should**

be positioned directly in front (no head rotation) of the user with the other screen(s) set off to the left and/or right

The primary display is the display viewed most frequently when multiple displays are present.

As with single displays, multiple displays **should**

be positioned between 50 cm (19.7 in.) and 100 cm (39.4 in.) from the eyes

Research suggests that repeatedly rotating the head/neck left and right may lead to upper-back muscle strain and discomfort (Camilleri, Bartha, Purvis, & Rempel, 2010). Perhaps due to the effects of head rotation, viewers of multiple displays tend to position the screens a little higher than a single screen (Camilleri et al., 2010).

4.4 Viewing angle

Viewing angle is the angle in the vertical plane between the horizontal line of sight and a defined visual target; see Figure 4-1. The entire visual area of a visual display terminal workstation **should**

be located between 0 degrees (eye level) and 50 degrees below eye level when the user assumes the upright sitting, forward-tilted sitting, or standing reference posture (see Figure 5-1)

For users without presbyopia—the age-related, progressive loss of the eye's ability to focus on nearby objects (accommodation), generally commencing in the mid-forties—the center of the visual display screen(s) **should**

be located 10 degrees to 20 degrees below eye level

For users who have presbyopia and vision correction with multifocal lenses, the center of the display **should**

be located 15 degrees to 40 degrees below eye level

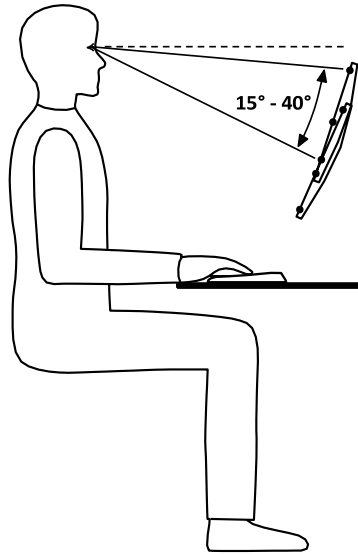

Figure 4-1 Viewing angles. In this diagram, two display positions are represented. The viewing angle to the top of the higher screen is -15 degrees, and the viewing angle to the center of the lower screen is -40 degrees.

Several field studies have reported that computer users position the center of the display as low as 40 degrees below the horizontal line of sight (Allie, Kokot, Bartha, & Purvis, 2009, 2010; Jaschinski et al., 1999).

For multiple display setups, the results of Camilleri et al.'s research suggest that rotating the neck to view two or more displays placed side-by-side, while looking downward, may tax the musculature more than when viewing a single display (Camilleri et al., 2010). Given these findings, when viewing two or more displays, the center of the screen should be positioned from 5 degrees to 10 degrees below the horizontal line of sight.

4.5 Display tilt angle

Tilt angle is the angle of the display at its center relative to vertical. Differences between the user's viewing angle and the display tilt angle may cause blurring of images presented on some screens (Burgess-Limerick, Plooy, & Ankrum, 1998). To minimize any such blurring, the angle of the surface of the display **should**

be perpendicular to a line from the eye to the center of the display

In order to accommodate computer users, including those who wear multifocal lenses, the display **shall**

have the capability to tilt from +10 degrees to -35 degrees (positive tilt is defined as the top of the display closer to the user than the bottom, and negative tilt as the bottom of the display closer than the top)

NOTE 1: This recommendation does not apply to displays designed for touch interaction with the user. Research results indicate that more than 40 degrees of negative tilt will be necessary to accommodate users

with touch-interactive displays (Shin & Zhu, 2012).

NOTE 2: The upper half of the screen tilts away from the user in negative tilt.

NOTE 3: ISO 9241-303 specifies that the display should permit the user to view the screen with a gaze angle from 0 degrees to 40 degrees and a head-tilt angle from 0 degrees to 25 degrees.

4.6 Spatial characteristics

As contemporary displays most often consist of discrete picture elements (pixels), the properties of these elements—such as their size, density, and number—determine the spatial characteristics of the display.

4.6.1 Pixel grid modulation, fill factor, and pixel pitch

Pixel grid modulation is the difference between the maximum and minimum luminance along a white display row, divided by the sum of maximum and minimum luminance (i.e., the contrast across display rows).

For displays having a pixel density of fewer than 30 pixels per degree of visual angle at the design viewing distance, the pixel grid modulation **shall not**

exceed 0.4 for monochrome and 0.7 for multicolor displays when all pixels are at maximum luminance

Compliance is established by the procedures specified in section 7.1 of the Society for Information Display (SID) Information Display Measurement Standard (IDMS) (2012). The *fill factor* is the surface available to present information (the pixel area) divided by the total display area. For flat-panel displays having a pixel density of fewer than 30 pixels per degree of visual angle at the design viewing distance, the fill factor **shall**

be at least 0.3 and **should**

be at least 0.5

Compliance is established by the procedures specified in section 7.4 of the SID IDMS standard (2012).

Pixel pitch, the distance between adjacent pixels from center to center, is determined by the design viewing distance (section 4.1), the height of characters in number of pixels (section 4.9.1), and the height of characters in visual angle (section 4.9.1). For example, if the design viewing distance is 50 cm (19.7 in.), the pixel pitch must be 0.25 mm (0.0098 in.) for characters 16 arc minutes high and 0.35 mm (0.013 in.) for characters 22 arc minutes high. Pixel pitch and the pixel grid modulation jointly determine the minimum pixel size for displays.

Pixel pitch **shall**

be specified by the manufacturer

4.6.2 Pixel and subpixel faults

The supplier **shall**

specify $Class_{\text{pixel}}$ of the display

The electronic display **should**

be free of pixel and subpixel faults, as defined in ISO 9241-307 (ISO, 2008); for example, section 5.2, Compliance, is established by the procedures specified in section 7.6 of the SID IDMS standard (2012)

4.7 Temporal quality

4.7.1 Response time

Response time is the time required for luminance changes to go from 10% to 90% of the luminance change.

The response time **shall**

be 20 ms or less to allow the transition between black and white and **should**

be less than the duration of a single frame

Longer response times can reduce the contrast of rapidly changing images, especially those that move and leave afterimages and visible trails behind moving objects (Holcombe, 2009).

Compliance is established by the procedures specified in section 10.2 of the SID IDMS standard (2012).

4.7.2 Flicker

The frames of displays with short response times **should**

be refreshed at a rate that exceeds the value defined by the following equations:

$$CFF = m + n\{\ln[T(f)]\}; \quad (4-1)$$

where

$$m = 14.62 - 7.89/\{1 + \exp[-(D - 42.3)/5.55]\}; \text{ and} \quad (4-2)$$

$$n = 11.33\{1 - \exp[-(0.735 + D/46.3)]\}. \quad (4-3)$$

$T(f)$ is the amplitude of the fundamental temporal frequency, f , of the display, measured in Trolands, and D is display size in degrees of visual angle. Troland (Td) is a unit of retinal illuminance, defined as the product

of the display luminance and the pupil area, representing the amount of light reaching the retina.

The Troland value, T , is obtained by multiplying luminance by the area of the pupil of the eye:

$$T = \pi(d/2)^2 L\Omega, \quad (4-4)$$

where d is the diameter of the pupil of the eye in mm, and $L\Omega$ is the mean luminance of the display in cd/m^2 , without reflected light or with the reflected light subtracted from the measured value (see SID IDMS standard [2012], section 11.2). Measurement of $L\Omega$ is described in the SID IDMS standard (2012), section 5.3.

The diameter of the pupil of the eye, d , of a typical observer can be estimated from the empirical equation (Moon & Spencer, 1944):

$$d = 5 - 3 \tanh[0.4 \log(L_T + 1)], \quad (4-5)$$

where L_T is the mean luminance of the display in cd/m^2 , including any reflected light. Note, however, that under any given set of conditions, there are large individual differences in pupil size among different individuals and even in a given individual at different times, and that pupil size tends to diminish with increasing age (Wyszecki & Stiles, 1982).

NOTE 1: It is important to note that the flicker tolerances reported here are based on the 1994 Moon and Spencer formula for estimating pupil diameter.

The fundamental temporal frequency of a display, f , is normally equal to the rate at which it is refreshed, but it can be measured according to the procedure described in the SID IDMS standard (2012), section 10.5. Alternatively, if the temporal response of display luminance follows an exponential curve with known time constant, α (in seconds), then the amplitude of the fundamental temporal frequency is given (Farrell, Benson, & Haynie, 1987) by the equation:

$$T(f) = 2T/[1 + (\alpha 2\pi f)^2]^{0.5} \quad (4-6)$$

The response time, α , can be measured according to the procedure described in the SID IDMS standard (2012), section 10.2.

Equation 4-1 estimates the minimum refresh rate at which no more than 10 percent of users report seeing flicker (Farrell et al., 1987). Equations 4-2 and 4-3 are empirical descriptions of the results of varying display size (Eriksson & Backstrom, 1987). Although the data cover only the range from 10 degrees to 70 degrees, both functions appear to approach an asymptote at the largest display sizes.

Flicker causes modest yet reliable increases in subjective reports of visual fatigue, increased task difficulty (Harwood & Foley, 1987), and reduced visual acuity (Murch, 1983).

Compliance is established by the measurements described earlier and by application of Equation 4-1 to the results.

It is important to note that this information is largely based on cathode ray tube (CRT) displays. More recent research on flicker and solid-state lighting (SSL) systems at the Lighting Research Center at Rensselaer Polytechnic Institute has suggested that two types of flicker—direct and indirect—are of concern with regard to solid state lighting and potentially of concern with regard to displays. Direct and indirect flicker might have effects on individuals' comfort and performance.

4.7.3 Direct and indirect flicker

Direct flicker is defined as the ability to directly perceive the frequency of modulation when it is relatively low (< 80 Hz). The indirect perception of flicker is a stroboscopic effect created by the interaction of the light source with moving objects.

A metric of direct flicker detectability has been suggested by a group of researchers at Rensselaer (Alliance for Solid-State Illumination Systems and Technologies, 2015). Similarly, a metric of the perceptibility and acceptability of indirect flicker also has been proposed (Alliance for Solid-State Illumination Systems and Technologies, 2012). These expanded definitions of flicker should be considered carefully in future revisions to this standard.

4.8 Color and luminance

4.8.1 Luminance range

The display **shall**

be capable of producing a luminance of at least 35 cd/m² and it **should**

be capable of producing at least 100 cd/m²

Users often prefer high display luminance (e.g., 100 cd/m² or greater), particularly under high ambient illumination. Moreover, reading speed and accuracy increase with increasing luminance, and legibility decreases below 35 cd/m² (Blackwell, 1946; Chung, Mansfield, & Legge, 1998; Giddings, 1972; Legge, Parish, Luebker, & Wurm, 1990; Legge, Pelli, Rubin, & Schleske, 1985; Legge, Rubin, & Luebker, 1987; Strasburger, Harvey, & Rentschler, 1991), as does color discrimination (Legge, Parish, et al., 1990; Pokorny & Smith, 1986).

Compliance is established by the procedures specified in section 6.1 of IEC 62341-6-1 (2017) with medium APL (Advanced Picture per Pixel Level) image loading.

4.8.2 Luminance nonuniformity

Luminance nonuniformity is the ratio of the maximum display luminance to the minimum when each is averaged over a 1-degree area at the design viewing distance.

The ratio of maximum luminance to minimum luminance of a display intended to be uniform **shall**

be 1.7 to 1 or less

Compliance is established by the procedures specified in section 8.1 of the SID IDMS standard (2012).

4.8.3 Luminance contrast and reflections

Luminance contrast ratio is defined here as the maximum luminance divided by the minimum luminance.

The display **shall**

exhibit a contrast ratio of at least 3 under all office illumination conditions

If the 3-to-1 ratio cannot be met, changing the location or orientation of the display so that it does not face windows or other sources of bright light might improve the contrast ratio.

Visibility improves by increasing up to a contrast ratio of 3, above which it rapidly levels off (Legge, Rubin, et al., 1987; Legge, Parish, et al., 1990; Strasburger et al., 1991). Luminance contrast is required because purely chromatic contrasts have poor visibility (Anderson, Mullen, & Hess, 1991; Chen & Yu, 1996; Legge, Rubin, et al., 1987; Legge, Parish, et al., 1990; Mullen, 1985; Sekiguchi, Williams, & Brainard, 1993). Aside from this low sensitivity of the visual system to isoluminant stimuli, the failure of isoluminant contrast to drive accommodation (Switkes, Bradley, & Schor, 1990; Wolfe & Owens, 1981) can further reduce retinal contrast, depending on the distance of the display relative to the distance of the observer's resting accommodation (Andre & Owens, 1999; Leibowitz & Owens, 1978). Note also that 8 percent to 10 percent of males of European ancestry have difficulty discriminating reds from greens (Pokorny & Smith, 1986). In addition, note that as users age, they require more contrast, approaching a factor of 3 at age 65, to produce a given visibility (Blackwell & Blackwell, 1971).

Excessive reflections from the display reduce display contrast and therefore legibility, and users object to them (Kubota, 1994; Kubota & Takahashi, 1989; Pawlak & Roll, 1990). Note that reflection of light from any source by an ordinary polished glass surface creates a virtual image with a luminance anywhere from 4 percent to 100 percent of that of the source itself, depending on the angle of incidence. Possible sources of reflected light include the sun, at $10^{9.5}$ cd/m²; filaments of tungsten sources, at $10^{6.3}$ cd/m²; fluorescent tubes, at $10^{4.2}$ cd/m²; blue sky, at $10^{3.4}$ cd/m²; and white office walls or desktops, at $10^{2.1}$ cd/m² (Makous, 1998). Hence, even reflections from the walls can be excessive, and direct reflections from almost any source are likely to be excessive. The best solution is often careful planning of the environment, including use of task lighting.

Compliance is established for a minimum contrast ratio of 3 by the procedures specified in section 11.9 of the SID IDMS standard (2012). In the absence of glare, the contrast ratio is completely determined by the illumination levels on the display for the workplace where the display is being used. When glare can be observed in the visual field, the procedure specified in section 11.9 of the SID IDMS standard (2012) is modified by

using the procedure in section 11.7.3 to include a glare directional source, such as of one of the sources mentioned in the foregoing paragraph.

4.8.4 Color uniformity

The chromaticity differences of a color, $\Delta(u'v')$, at different locations on the display that is intended to be uniform **should**

be no greater than 0.03 and no greater than 0.02 within any area subtending less than 40 degrees of visual angle

The ability of the eye to detect chromaticity differences decreases with increasing separation of targets (Sharpe & Wyszecki, 1976).

Compliance is established by the procedures specified in section 8.1 of the SID IDMS standard (2012).

4.9 Information format

4.9.1 Character height

The height of a character is typically specified by the height of the lower-case x character. The minimal x height in body text **should**

be 16 arc minutes

Comfortable, efficient reading requires minimally 22 arc minutes (Chung, Mansfield, et al., 1998; Giddings, 1972; Legge, Pelli, et al., 1985; Legge, Rubin, et al., 1987; Legge, Parish, et al., 1990; Strasburger et al., 1991). However, character size **should**

be below 30 arc minutes to avoid slowing down reading by reducing the number of characters that can be viewed foveally during a fixation (Arditi, Knoblauch, & Grunwald, 1990; Legge, Rubin, et al., 1987).

An exception to the upper limit on character height may be useful with poorer screen resolution, or for users with presbyopia, or for those with poor visual acuity (20/70 or poorer), all of whom may require larger character height.

The height of characters with less than a 3:1 contrast relative to the background (Chen & Yu, 1996; Legge, Parish, et al., 1990; Sekiguchi et al., 1993) **should**

be 30 arc minutes or greater

Where speed of recognition is unimportant, such as footnotes, subscripts, and superscripts, character height can be as low as 12 arc minutes. Warnings and other essential information require larger characters to ensure accurate and speedy recognition.

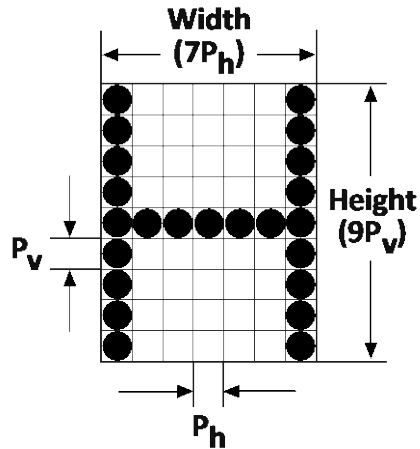

Figure 4-2. Dimensions of characters. The height and width of characters are defined by this figure. Squares represent pixels. P_v and P_h represent the vertical and horizontal dimensions of a pixel, respectively.

4.9.2 Character width-to-height ratio

Character width-to-height ratio is based on the lowercase letter *x* and uppercase letter *H* without serifs. The range of width-to-height ratio (Width/Height in Figure 4-2) **shall**

be between 0.5:1 and 1:1

and, for optimal legibility and readability, **should**

be between 0.6:1 and 0.9:1

These ratios are based on a character width of at least 4 pixels for lowercase letters and 5 pixels for uppercase letters.

The width-to-height ratio **shall**

be adapted to different character formats and viewing conditions and optimally **should**

be 0.78:1 for continuous reading of lowercase Latin alphanumeric characters and 0.71:1 for uppercase letters and numerals

Subscripts, superscripts, and the numerals in fractions **should**

have a 0.82:1 ratio

The width-to-height ratio **should**

increase for viewing from a horizontal angle

The increase **should**

be proportional, with a 0.7:1 to 1.3:1 ratio when viewing from a 40-degree angle

In the unusual condition of increased vertical viewing angle, similar consideration in increasing height-to-width ratio **should**

be given

Legibility is sometimes sacrificed to some extent for aesthetics, conservation of space, or other practical considerations (Benson & Farrell, 1988; Soar, 1955). This can be remedied by using larger inter-letter spacing or character size.

For the purpose of identifying individual characters, the same ratios **shall**

be maintained, but a smaller character size can be used

Antialiasing fonts require a larger character size to permit a similar rate of letter and word recognition.

4.9.3 Stroke width

The stroke width of characters (a multiple of P_h and P_v in Figure 4-2) **shall**

be from 10 percent to 16 percent of the minimal character height, and at least one pixel width (see Figure 4-2)

Wider strokes are better for black text on a white background than for the opposite polarity (Berger, 1944; Grether & Baker, 1972; Kuntz & Sleight, 1950; Shapiro, 1951; Uhlener, 1941).

If a display provides positive and negative polarities, it **shall**

meet all the requirements of section 4.8.1 for either positive or negative polarity

Stroke width **should**

be increased when antialiasing renderings are used to maintain the structural integrity of individual characters

4.9.4 Spacing between characters

The spacing between characters, S_c , without serifs **shall**

be at least equal to the stroke width (e.g., for adjacent *i*'s)

and **shall**

be 25 percent (for narrower character format) to 60 percent (for wider format) of the width of uppercase letters (see Figure 4-3)

The spacing between characters with serifs **shall**

be at least 20 percent of *H* width (and at least one pixel) between the two strokes of adjacent letters (see Figures 4-2 and 4-3)

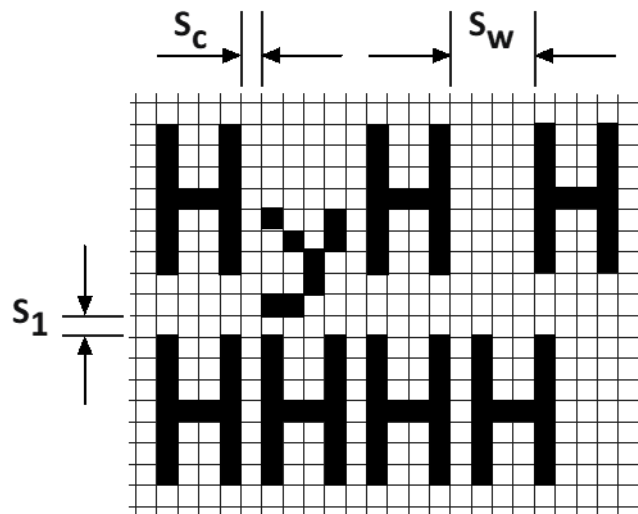

Figure 4-3. Spacing between characters (S_c), lines (S_l), and words (S_w). Squares represent pixels.

This recommendation concerns both the effects of crowding (Arditi et al., 1990; Chung, Levi, & Legge, 2001; Leat, Li, & Epp, 1999; Martelli, Majaj, & Pelli, 2005; Pelli, Palomares, & Majaj, 2004; Strasburger et al., 1991) and degraded legibility caused by excessive spacing.

Spacing **should**

be increased for angled viewing and for antialiasing rendering, as both reduce the actual physical distance between the adjacent edges of letters

4.9.5 Spacing between words

The spacing between words (S_w in Figure 4.3) **shall**

exceed the spacing between characters (S_c in Figure 4-3) and should be at least 50 percent of the

width of an uppercase letter *H* without serifs (see Figure 4-2)

4.9.6 Spacing between lines

The space between lines of text (*S*) in Figure 4-3), including diacritics, **should**

be at least 15 percent (and at least one pixel) of *H* height between any strokes of vertically neighboring lines of letters (see Figure 4-2)

Users with partial vision or ocular difficulties in maintaining eye fixation require larger spacing of 25 percent to 30 percent.

4.10 Compliance

Compliance for the sections on character height, sizes of colored characters, character width-to-height, stroke width, character format, spacing between characters, spacing between lines, and spacing between words is established by inspection of the display under sufficient magnification to resolve individual pixels.

References

- Alliance for Solid-State Illumination Systems and Technologies. (ASSIST). (2012). *ASSIST recommends... Flicker parameters for reducing stroboscopic effects from solid-state lighting systems* (Vol. 11, Iss. 1, May). Troy, NY: Lighting Research Center.
- Alliance for Solid-State Illumination Systems and Technologies (ASSIST). 2015. *ASSIST recommends... Recommended metric for assessing the direct perception of light source flicker* (Vol. 11, Iss. 3, January). Troy, NY: Lighting Research Center.
- Allie, P., Kokot, D., Bartha, M., & Purvis, C. (2009). Computer display placement for progressive addition lens wearers: A field observation of multiple display conditions. In *Proceedings of the Human Factors and Ergonomics Society 53rd Annual Meeting* (pp. 493–497). Human Factors and Ergonomics Society.
- Allie, P., Kokot, D., Bartha, M., & Purvis, C. (2010). A field observation of display placement requirements for presbyopic and prepresbyopic computer users. In *Proceedings of the Human Factors and Ergonomics Society 54th Annual Meeting* (pp. 709–713). Human Factors and Ergonomics Society.
- Anderson, S. J., Mullen, K. T., & Hess, R. F. (1991). Human peripheral spatial resolution for achromatic and chromatic stimuli: Limits imposed by optical and retinal factors. *Journal of Physiology*, *442*, 47–64.
- Andre, J. T., & Owens, D. A. (1999). Predicting optimal accommodative performance from measures of the dark focus of accommodation. *Human Factors*, *41*, 139–145.
- Arditi, A., Knoblauch, K., & Grunwald, I. (1990). Reading with fixed and variable character pitch. *Journal of the Optical Society of America A*, *7*, 2011–2015.
- Benson, B. L., & Farrell, J. E. (1988). The effect of character height-to-width ratio of CAT display legibility. *SID Symposium Digest of Technical Papers*, 340–343.
- Berger, C. (1944). Stroke-width, form and horizontal spacing of numerals as determinants of the threshold of recognition. *Journal of Applied Psychology*, *28*, 208–231.
- Blackwell, H. R. (1946). Contrast thresholds of the human eye. *Journal of the Optical Society of America*, *36*, 624–643.
- Blackwell, O. M., & Blackwell, H. R. (1971). Visual performance data for 156 normal users of varying age.

- Journal of the Illuminating Engineering Society*, 61, 3–13.
- Burgess-Limerick, R., Plooy, A., & Ankrum, D. (1998). The effect of imposed and self-selected computer monitor height on posture and gaze angle. *Clinical Biomechanics*, 13, 584–592.
- Camilleri, M. J., Bartha, M. C., Purvis, C. J., & Rempel, D. M. (2010). Neck biomechanics and multiple wide computer displays. In *Proceedings of the Human Factors and Ergonomics Society 54th Annual Meeting* (pp. 551–555). Human Factors and Ergonomics Society.
- Carlson, D. R., & Cohen, R. W. (1978). *Visibility of displayed information* (ONR-CR213-120-4F). Office of Naval Research.
- Charness, N., Dijkstra, K., Jastrzembski, T., Weaver, S., & Champion, M. (2008). Monitor viewing distance for younger and older workers. In *Proceedings of the Human Factors and Ergonomics Society 52nd Annual Meeting* (pp. 1614–1617). Human Factors and Ergonomics Society.
- Chen, T.-L., & Yu, C.-Y. (1996). The relationship between visual acuity and color contrast in the OSA uniform color space. *Color Research and Application*, 21(1), 18–25.
- Chung, S. T., Mansfield, J. S., & Legge, G. E. (1998). Psychophysics of reading. XVIII. The effect of print size on reading speed in normal peripheral vision. *Vision Research*, 38, 2949–2962.
- Chung, S. T. L., Levi, D. M., & Legge, G. E. (2001). Spatial-frequency and contrast properties of crowding. *Vision Research*, 41, 1833–1850.
- Collins, C. C., O'Meara, D., & Scott, A. B. (1975). Muscle tension during unrestrained human eye movements. *Journal of Physiology*, 245, 351–369.
- Commission Internationale de L'Eclairage. (CIE). (1994). *Industrial colour-difference evaluation* (pp. 116–1995). Author.
- Eriksson, S., & Backstrom, L. (1987). Temporal and spatial stability in visual displays. In B. Knave & P.-G. Wideback (Eds.), *Work with display units*. North Holland.
- Eriksson, W. (1992). Perceptual thresholds for jitter in VDUs. *Displays*, 13(4), 187–192.
- Farrell, J. E., Benson, B. L., & Haynie, C. R. (1987). Predicting flicker thresholds for video display terminals. In *Proceedings of the Society for Information Display*, 28, 449–453.
- Fisher, R. F. (1977). The force of contraction of the human ciliary muscle during accommodation. *Journal of Physiology*, 270, 51–74.
- Foley, J. M. (1994). Human luminance pattern-vision mechanisms: Masking experiments require a new model. *Journal of the Optical Society of America A*, 11, 1710–1719.
- Foley, J. M., & Chen, C. C. (1999). Pattern detection in the presence of maskers that differ in spatial phase and temporal offset: Threshold measurements and a model. *Vision Research*, 39, 3855–3872.
- Giddings, B. J. (1972). Alpha-numerics for raster displays. *Ergonomics*, 15, 65–72.
- Grether, W. F., & Baker, C. A. (1972). Visual presentation of information. In H. P. Van Cott & R. G. Kincade (Eds.), *Human engineering guide to equipment design* (pp. 41–121). McGraw-Hill.
- Harwood, K., & Foley, P. (1987). Temporal resolution: An insight into the video display terminal (VDT) "problem." *Human Factors*, 29, 447–452.
- Holcombe, A. O. (2009). Seeing slow and seeing fast: Two limits on perception. *Trends in Cognitive Science*, 13(5), 216–221.
- International Electrotechnical Commission. (IEC). (2017). *IEC 62341-6-1: Organic light-emitting diode (OLED) displays—Part 6-1. Measuring methods of optical and electro-optical parameters*. Author.
- International Organization for Standardization. (ISO). (2008). *ISO 9241-307: Ergonomics of human-system interaction—Part 307: Analysis and compliance test methods for electronic visual displays*. Author.

- International Organization for Standardization. (ISO). (2011). *ISO 9241-303:2011 – Ergonomics of human-system interaction – Part 303: Requirements for electronic visual displays*. Author.
- Jaschinski, W., Heuer, H., & Kylian, H. (1998). Preferred position of visual displays relative to the eyes: A field study of visual strain and individual differences. *Ergonomics*, *41*, 1034–1049.
- Jaschinski, W., Heuer, H., & Kylian, H. (1999). A procedure to determine the individually comfortable position of visual displays relative to the eyes. *Ergonomics*, *43*, 535–549.
- Jaschinski-Kruza, W. (1988). Visual strain during VDU work: The effect of viewing distance and dark focus. *Ergonomics*, *31*, 1449–1465.
- Jaschinski-Kruza, W. (1990). On the preferred viewing distances to screen and document at VDU workplaces. *Ergonomics*, *33*, 1055–1063.
- Jaschinski-Kruza, W. (1991). Eyestrain in VDU users: Viewing distance and the resting position of ocular muscles. *Human Factors*, *33*, 69–83.
- Kramer, D., & Fahle, M. (1996). A simple mechanism for detecting low curvatures. *Vision Research*, *36*, 1411–1419.
- Kubota, S. (1994). Effects of surface reflection properties of VDT screens on subjective ratings of the reflected glare disturbances from the different size sources.
- Kubota, S., & Takahashi, M. (1989, June). Permissible luminance of disturbing reflections of light sources on CRT displays. *Japan Illuminating Engineering Society Journal*, 314–318.
- Kuntz, J. E., & Sleight, R. B. (1950). Legibility of numerals: The optimal ratio of height to width of stroke. *American Journal of Psychology*, *63*, 567–575.
- Leat, S. J., Li, W., & Epp, K. (1999). Crowding in central and eccentric vision: The effects of contour interaction and attention. *Investigative Ophthalmology and Visual Science*, *40*, 504–512.
- Legge, G. E., & Foley, J. M. (1980). Contrast masking in human vision. *Journal of the Optical Society of America*, *70*, 1458–1471.
- Legge, G. E., Parish, D. H., Luebker, A., & Wurm, L. H. (1990). Psychophysics of reading. XI. Comparing color contrast and luminance contrast. *Journal of the Optical Society of America A*, *7*, 2002–2010.
- Legge, G. E., Pelli, D. G., Rubin, G. S., & Schleske, M. M. (1985). Psychophysics of reading—I. Normal vision. *Vision Research*, *25*, 239–252.
- Legge, G. E., Rubin, G. S., & Luebker, A. (1987). Psychophysics of reading—V. The role of contrast in normal vision. *Vision Research*, *27*, 1165–1177.
- Leibowitz, H. W., & Owens, D. A. (1978). New evidence for the intermediate position of relaxed accommodation. *Documenta Ophthalmologica*, *46*, 133–147.
- Makous, W. (1998). Optics and photometry. In R. H. S. Carpenter & J. G. Robson (Eds.), *Vision research: A practical guide to laboratory methods* (pp. 1–49). Oxford University Press.
- Mandler, M. B., & Makous, W. (1984). A three-channel model of temporal frequency perception. *Vision Research*, *24*, 1881–1887.
- Martelli, M., Majaj, N. J., & Pelli, D. G. (2005). Are faces processed like words? A diagnostic test for recognition by parts. *Journal of Vision*, *5*(1), 58–70.
- Miller, G. A. (1956). The magical number seven, plus or minus two: Some limits on our capacity for processing information. *Psychological Review*, *63*(2), 81–97.
- Moon, P., & Spencer, D. E. (1944). Visual data applied to lighting design. *Journal of the Optical Society of America*, *34*, 605–617.
- Mullen, K. T. (1985). The contrast sensitivity of human colour vision to red-green and blue-yellow chromatic

- gratings. *Journal of Physiology*, 359, 381–400.
- Murch, G. M. (1983). Visual fatigue and operator performance with DVST and raster displays. *Proceedings of the Society for Information Display*, 24(1), 53–61.
- Olzak, L. A., & Thomas, J. P. (1986). Seeing spatial patterns. In K. R. Boff, L. Kaufman, & J. P. Thomas (Eds.), *Handbook of perception and human performance* (Vol. 1, Chap. 7). Wiley.
- Pawlak, U., & Roll, K.-F. (1990). VDTs: Setting levels for reflected luminance. *Siemens Review*, 27–29.
- Pelli, D. G., Palomares, M., & Majaj, N. J. (2004). Crowding is unlike ordinary masking: Distinguishing feature integration from detection. *Journal of Vision*, 4, 1136–1169.
- Pokorny, J., & Smith, V. C. (1986). Colorimetry and color discrimination. In K. R. Boff, L. Kaufman, & J. P. Thomas (Eds.), *Handbook of perception and human performance* (Vol. 1, pp. 8-1–8-51). Wiley.
- Psihogios, J. P., Sommerich, C. M., Mirka, G. M., & Moon, S. D. (2001). A field evaluation of monitor placement effects in VDT users. *Applied Ergonomics*, 32(4), 313–325.
- Sekiguchi, N., Williams, D. R., & Brainard, D. H. (1993). Efficiency in detection of isoluminant and isochromatic interference fringes. *Journal of the Optical Society of America A*, 10, 2118–2133.
- Shapiro, H. B. (1951). Factors affecting the legibility of digits. *The American Psychologist*, 6, 364.
- Sharpe, L. T., & Wyszecki, G. (1976). Proximity factor in color-difference evaluations. *Journal of the Optical Society of America*, 66, 40–49.
- Shin G., & Zhu, Z. (2012). User discomfort, work posture and muscle activity while using a touchscreen in a desktop PC setting. *Ergonomics* 54, 733–744.
- Soar, R. S. (1955). Height-width proportion and stroke width in numeral visibility. *Journal of Applied Psychology*, 39, 43–79.
- Sommerich, C. M., Joines, S. M. B., & Psihogios, J. P. (2001). Effects of computer monitor viewing angle and related factors on strain, performance, and preference outcomes. *Human Factors*, 43, 39–55.
- Stein, I. H. (1978). *The effect of active area on the legibility of dot matrix displays*. U.S. Army Electronics Research and Development Command.
- Strasburger, H., Harvey, L. O., Jr., & Rentschler, I. (1991). Contrast thresholds for identification of numeric characters in direct and eccentric view. *Perception & Psychophysics*, 49, 495–508.
- Switkes, W., Bradley, A., & Schor, C. (1990). Readily visible changes in color contrast are insufficient to stimulate accommodation. *Vision Research*, 30, 1367–1376.
- Turner, M. J. (1958). Observations on the normal subjective amplitude of accommodation. *British Journal of Physiological Optics*, 15, 428–450.
- Tyler, C. W., & Torres, J. (1972). Frequency response characteristics for sinusoidal movement in the fovea and periphery. *Perception and Psychophysics*, 12, 232–236.
- Uhlner, J. E. (1941). The effects of thickness of stroke on the legibility of letters. *Proceedings of the Iowa Academy of Science*, 48, 319–324.
- Society for Information Display. (SID). (2012). *Information display measurement standard* (Version 1.03). Author.
- Watson, A. B., & Yellott, J. I. (2012). A unified formula for light-adapted pupil size. *Journal of Vision*, 12(10), 12.

- Wittke, J. P. (1987). Moiré considerations in shadow mask picture tubes. *Proceedings of the Society for Information Display*, 28(4), 415–418.
- Wolfe, J. M., & Owens, D. A. (1981). Is accommodation colorblind? Focusing chromatic contours. *Perception*, 10, 53–62.
- Wyszecki, G., & Stiles, W. (1982). *Color science: Concepts and methods, quantitative data and formulae* (2nd ed.). New York: Wiley.
- Yang, J., & Makous, W. (1995). Modeling pedestal experiments with amplitude instead of contrast. *Vision Research*, 35, 1979–1989.
- Yang, J., Qi, X., & Makous, W. (1995). Zero frequency masking and a model of contrast sensitivity. *Vision Research*, 35, 1965–1978

Chapter 5 Workstation Furniture and Accessories

5.0 Purpose and scope

The purpose of this chapter is (1) to establish design specifications for computer workstations that support and fit the intended user during text-, data-, and graphics-processing tasks; and (2) to provide specifications and guidance to individuals who have responsibilities for acquiring, installing, and integrating computer workstations.

The scope of this chapter covers design features for computer work surfaces, display supports and support surfaces and input device support surfaces, chairs, and supports for users' feet, wrists, hands, and forearms.

5.1 Introduction

The specifications presented in this chapter are product-centered and should be used for product design, requirements, and selection purposes by furniture designers, manufacturers, specifiers, and end users.

This chapter presents design specifications for chairs, tables, and accessories used in computer workstations. The furniture specifications are based on anthropometric considerations associated with four basic whole-body reference postures: upright sitting, reclined sitting, forward-tilted sitting, and standing (see Figure 5-1).

This chapter also presents specifications and guidance to employers and the individuals who employers designate to configure computer workstations and the immediately surrounding workplace environment for the individual user. In addition to furniture, these workstations consist of input devices and visual displays that conform with component specifications stated elsewhere in the standard (i.e., Chapter 3, Input Devices; and Chapter 4, Electronic Displays).

5.2 Anthropometry

The anthropometric data are based on the Society of Automotive Engineers' Civilian American and European Surface Anthropometry Resource (CAESAR) anthropometric database (SAE CAESAR Measurements; Robinette, Blackwell, Daanen, Boehmer, & Fleming, 2002) and are weighted to match the demographics of the 2011–2014 NHANES (Fryar, Gu, Ogden, & Flegal, 2016) anthropometric survey. Additionally, as there were fewer individuals in the high body mass index (BMI) range of the CAESAR data than desired, the CAESAR data were supplemented with high BMI data supplied by the University of Michigan Transportation Research Institute (UMTRI) utilizing appropriate statistical methods.

5.2.1 Virtual Fit Test Tool

The HFES Virtual Fit Tool (VFT) is a user-friendly, spreadsheet-based application designed to simplify the analysis of multivariate anthropometric accommodation. It enables designers to evaluate how well a product physically fits its intended user population by simulating accommodation across multiple body dimensions. The tool uses anthropometric data from the U.S. civilian population, including the CAESAR data set and a University of Michigan study that aligns distributions of stature, body weight, and BMI by gender. Designers can specify gender proportions and input product dimensions—such as seat width, depth, and height—to

determine the percentage of users concurrently accommodated across all variables.

Unlike univariate methods that assess fit based on a single measurement, the VFT supports multivariate analysis, offering a more realistic and inclusive approach to ergonomic design. This capability is particularly valuable for adjustable components in computer workstations, helping ensure compliance with ergonomics standards and improving usability for a diverse user base.

Some of the limitations of the VFT tool include its assumption of independence between variables and the tool's inability to account for dynamic postures. The VFT focuses on physical fit and cannot incorporate task demands.

Specifying 5th to 95th percentile values for each dimension (the univariate approach taken in previous versions of this standard) generally will not accommodate 90 percent of all individuals on all dimensions concurrently, as demonstrated with modern statistical models (Dainoff, Gordon, Robinette, & Strauss, 2003; Gordon, Corner, & Brantley, 1997; Guan et al., 2012; Kreifeldt & Nah, 1995; Kroemer, 1984; Kroemer, Kroemer, & Kroemer-Elbert, 1994; Robinette & McConville, 1981; Ziolk & Wawrow, 2004).

The VFT addresses this problem, directly indicating the estimated proportion of the intended users (U.S. civilians) who are concurrently accommodated on all dimensions entered in the tool. The VFT was used to develop accommodation estimates for the required product dimensions given in this chapter. Final accommodation of a design from the specifications in this standard could also be verified by using actual fit with the end user, in their apparel, personal preferences, and job-specific requirements (Dainoff et. al., 2003; refer to the Virtual Fit Multivariate Anthropometric Tool at <https://www.hfes.org/Publications/Technical-Standards>).

NOTE: The terms “user,” “operator,” and “worker” are used interchangeably in this chapter.

5.3 Conformance

A product or system conforms to this standard when it meets all the pertinent requirements or “**shall**” statements. “**Should**” statements do not affect conformance. See section 1.1 Conformance.

5.3.1 Dimensional specifications for workstation components

To conform to this standard, the required dimensions of a product or product system **shall**

concurrently accommodate 90 percent of the intended users on all required dimensions

It might not be possible, or even desirable, for a single product to accommodate 90 percent of all intended users concurrently on multiple dimensions. In such cases, a system of two or more related products—for example, a “small” model chair and an “average” model chair—that jointly accommodate 90 percent of all intended users is deemed to conform with this standard as a system.

5.4 Postures and acceptable ranges

5.4.1 Whole-body postures

This standard recognizes that computer workstation users frequently change their working postures to maintain comfort and productivity. Four whole-body reference postures are used in this standard to represent a range of whole-body postures observed at computer workstations (see Figure 5-1).

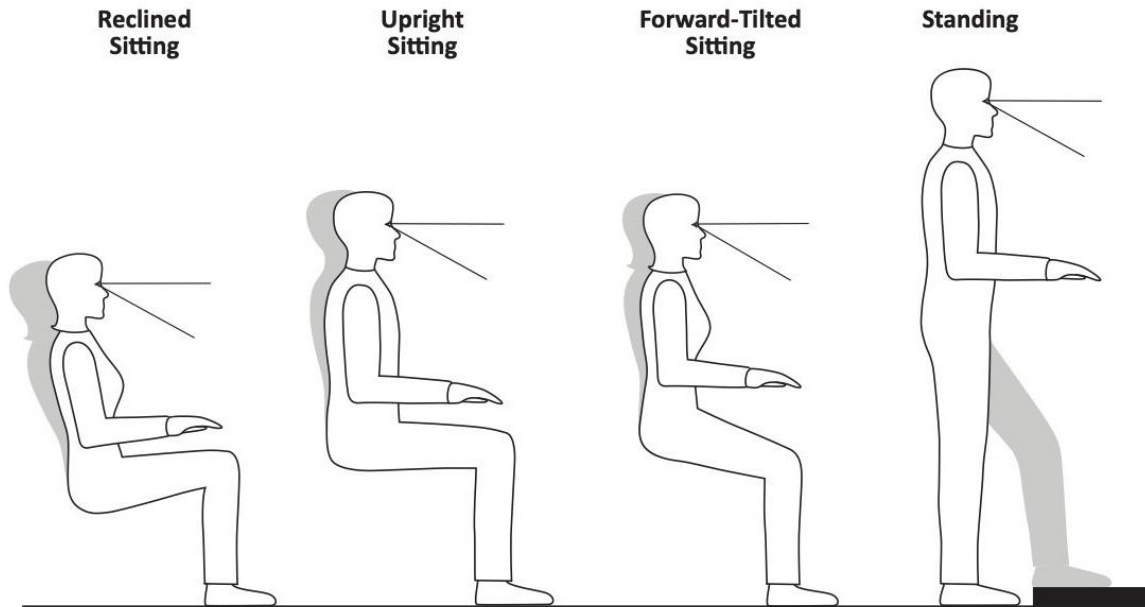

Figure 5-1. Whole-body reference postures for computer workstation users.

The four whole-body reference postures are characterized as follows:

Reclined sitting. In the reclined sitting posture, the user's torso and neck recline between 105 and 120 degrees relative to horizontal.

Upright sitting. In the upright sitting posture, the user's torso and neck are approximately vertical and in line (between 90 and 105 degrees to the horizontal), the thighs are approximately horizontal, and the lower legs are vertical.

Forward-tilted sitting. In the forward-tilted sitting posture, the user's thighs, from hip to knee, are inclined downward below the horizontal, the torso is vertical or slightly reclined behind the vertical, and the angle between the thighs and the torso is greater than 90 degrees.

NOTE: The previous version of this standard used the term "declined sitting" rather than the equivalent term, "forward-tilted sitting."

Standing. In the standing posture, the user's legs, torso, neck, and head are approximately in line and vertical. One foot is often supported on a footrest while the other is supported on the floor.

Users require frequent movement and postural changes to achieve and maintain comfort and productivity (Cushman, 1984; Sanders & McCormick, 1993). The four reference postures are intended to illustrate the diversity of body positions observed at computer workstations. Because these reference postures are intended as examples of human postures, variations in actual postures observed during work sessions can be expected. However, not all postures might be equally comfortable or applicable to all tasks.

5.4.2 User postures

The installed workstation shall

allow users to adopt postures within the following reference postural design criteria for body segments:

- Elbow angles between 70 and 135 degrees. See Figure 5.2 for an illustration of the range of acceptable elbow angles.
- Shoulder abduction angles less than 20 degrees. See Figure 5-3 for an illustration of the range of acceptable shoulder abduction angles.
- Shoulder flexion angles less than 25 degrees. See Figure 5-4 for an illustration of the range of acceptable shoulder flexion angles.
- Wrist flexion and extension angles less than 30 degrees (Hedge, McCrobie, Morimoto, Land, & Rodriguez, 1995; Rempel & Horie, 1994). See Figure 5-5 for an illustration of the range of acceptable wrist angles.
- Torso-to-thigh angles equal to or greater than 90 degrees (Chaffin, Andersson, & Martin, 1984). See Figure 5-6 for an illustration of the range of acceptable torso-to-thigh angles.

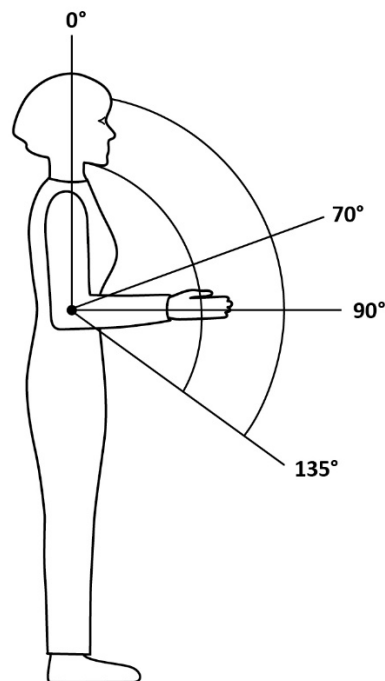

Figure 5-2. Acceptable range of elbow angles.

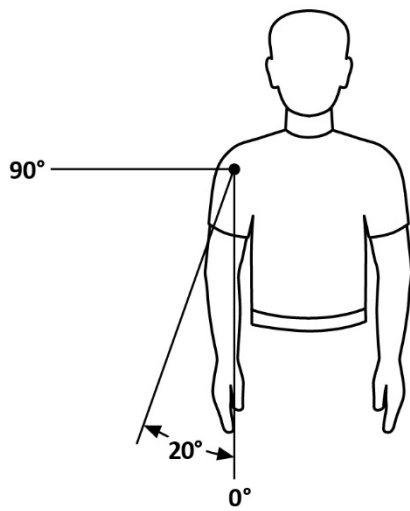

Figure 5-3. Acceptable range of shoulder abduction angles.

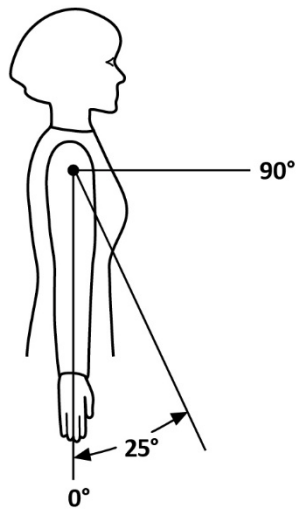

Figure 5-4. Acceptable range of shoulder flexion angles.

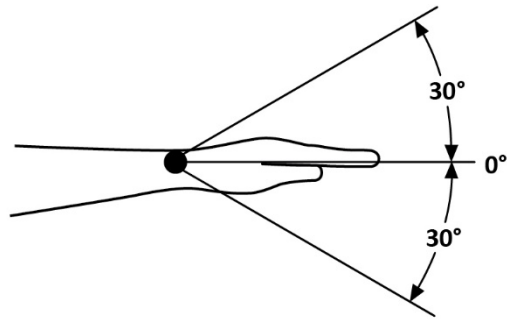

Figure 5-5. Acceptable range of wrist flexion and extension angles.

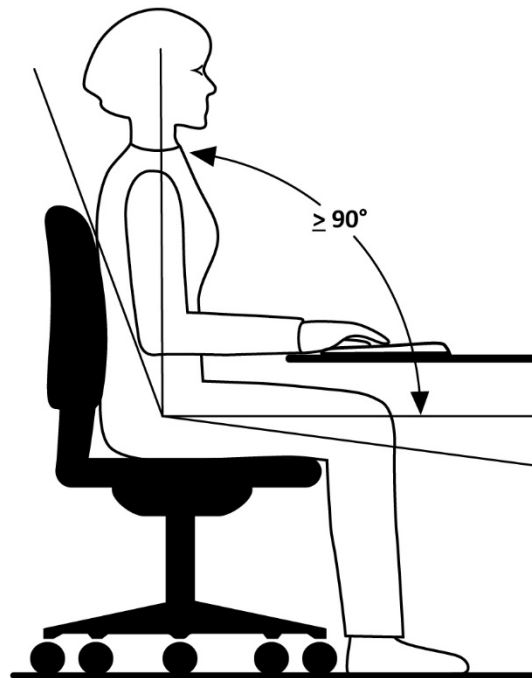

Figure 5-6. Acceptable range of torso-to-thigh angles.

5.5 Installation and configuration of computer workstations

The installation and configuration of computer workstations involves several key considerations.

Employers **should**

ensure that individual hardware components, such as work surfaces and chairs, conform to the

required design specifications stated elsewhere in this standard

Employers **should**

ensure that the configured workstation is properly adjusted to fit users individually and

ensure that users are informed about the proper use and adjustment of the workstation components (Robertson, Ciriello, & Garabet, 2013)

NOTE: An employer is defined as the individual or organization responsible for the proper workstation setup. Typically, the employer will contract with facility designers, interior designers, facility managers, installers, system integrators, in-house health and safety professionals, ergonomists, and the like to provide the necessary workstation initial design, setup, adjustments, and maintenance to ensure compliance with this standard.

5.6 Dimensional measurements

To determine dimensional compliance, portions of this standard that refer to seating-related measurements should use a standard chair-measuring device (CMD) as specified by either BIFMA CMD-1-2013 Universal Measurement Procedure for the Use of BIFMA Chair Measuring Device, or ISO 24496, Chair Measuring Method. The ISO Chair Measuring Device per ISO/TR 24496:2017 “Office furniture - Office work chairs - Methods for the determination of dimensions” has been determined to provide acceptable results and may be used to measure a chair according to this guideline. Devices other than a CMD should not be used to determine if a product meets the dimensional and adjustment ranges in this guideline.

5.7 Adjustment controls in the workstation

Controls used for the adjustment of workstation components **shall not**

intrude into the leg and foot clearance spaces when not in use and

interfere with users’ typical work activities or pose hazards during use

Adjustment controls **should**

be usable by users while in the relevant reference postures

Some user groups may have special requirements regarding adjustment controls. Considerations for these user groups include the following:

inadvertent activation of controls while tactilely locating and identifying the control or controls;

ability to use two hands for control activation;

limits on the ability to exert force, or the ability to grasp, pinch, or twist the wrist; and
ability to discern the status of locking or toggle controls through touch or sound.

Controls for adjustable workstation surfaces **shall**

use a fail-safe mechanism to prevent inadvertent movement and

use a control-locking mechanism to prevent inadvertent operation

5.8 Pinch points

Pinch points, in which fingers, arms, and legs can be caught between movable surfaces or parts, **shall**

be avoided by means of design or guarding

Pinch points dimension **should**

be less than 8 mm (0.32 in.) or greater than 25 mm (1.0 in.)

The recommended hierarchy of procedures to avoid pinch points is to:

1. design to eliminate the hazard,
2. guard against the hazard,
3. provide warning labels and instructions to users for safe operation.

5.9 Radii of edges

All work surface edges directly in front of the user **should**

have radii of at least 3 mm

Other edges of the work surface with which the user may contact **should**

have radii of at least 2 mm

5.10 Device cabling

Cables that connect to devices in the workstation **should**

be placed to avoid interference with the operation of workstation components and

be placed to avoid creating hazards for people or equipment in the workstation

5.11 Clothing and movement allowances

Anthropometric measurements for the CAESAR database used in this standard were collected with participants wearing tight fabrics and no shoes to obtain accurate surface anthropometry. Given that this standard will be used by (a) experts and practitioners from the field of human factors and ergonomics, as well as (b) individuals who may not be familiar with anthropometric clothing and movement allowances, the dimensions given in this standard will reflect both the minimally clothed dimensions as well as industry-accepted clothing and movement allowances.

This approach should minimize use errors of someone using the standard anthropometric dimension for a workstation application without accounting for allowance of the individual. Different allowances may be applied for different clothing and demographic situations. For those cases, the standard anthropometric dimension will always be the foundation for calculation.

Table 5-1. Suggested Clothing and Movement Allowances

Allowance	Description	Value
Shoe Allowance	The height of the user's shoe that will raise the foot from the floor. This may affect seat height, standing eye height, and other vertical dimensions. Different applications or environments may need to use a different allowance.	30 mm (1.2 in.)
Clothing Allowance	Thickness of clothing that would be worn by the individual instead of tight-fitting anthropometric clothing, accommodates for extra space where applicable.	4 mm (0.2 in.)
Movement Allowance	Splaying or movement of limbs beyond the standard anthropometric posture that will accommodate more natural or relaxed postures, such as thighs abducting from the body while sitting and needing clearance under a desk.	45 mm (1.8 in.)
Clearance Allowance	Extra space needed to allow clearance of a portion of the body not to have contact with a product. For example, extra	10 mm (0.4 in.)

	clearance for the popliteal area on seat depth so that extra pressure is not against the popliteal area from the seat cushion.	
--	--	--

5.12 Work surfaces

This section contains specifications for work surfaces used with the four reference postures.

5.12.1 Definitions for work surfaces

5.12.1.1 Support surfaces

- **Primary work surface:** The main surface where the user will be performing most computer-related tasks.
- **Display (or monitor) support:** A surface or another device used to support a display at a workstation.
- **Input device support surface:** A surface such as a table, desk-top, or keyboard tray used to support input devices such as keyboard, mouse, and so on.

5.12.1.2 Adjustable surfaces

Adjustable workstation surfaces **shall**

use a fail-safe mechanism to prevent inadvertent movement and

use a control-locking mechanism to prevent inadvertent operation

5.13 Primary work surface

The primary work surface top **should**

be at least 681 mm (26.8 in.) wide and accommodate the user postural design criteria described in 5.4.2, User postures

The most commonly used objects **should**

be placed in the primary work zone

The depth of the primary work surface **should**

allow a viewing distance of at least 500 mm (19.7 in.),

allow positioning of the display so that the angle between the horizontal level of the eyes and the center of the screen ranges between 15 degrees and 25 degrees, and

allow positioning of the entire viewing area (e.g., including the keyboard) within 60 degrees below horizontal eye level

NOTE 1: Multifocal lens wearers may prefer to place the center of the screen at the lower end of the recommended range, or slightly lower.

NOTE 2: A viewing distance ranging between 500 mm (19.7 in.) and 750 mm (29.5 in.) or even greater is common among groups of users.

5.14 Work zones

A work zone (Figure 5-7) is an area on the work surface within which the user can access various input devices and tools.

- **Primary work zone:** The area nearest the user where it is easiest to reach and move while in a seated or standing posture.
- **Secondary work zone:** The area beyond the primary work zone that requires some effort to reach and move while in a seated or standing posture.
- **Tertiary work zone:** The area beyond the secondary work zone that requires the most effort to reach and move while in a seated or standing posture.

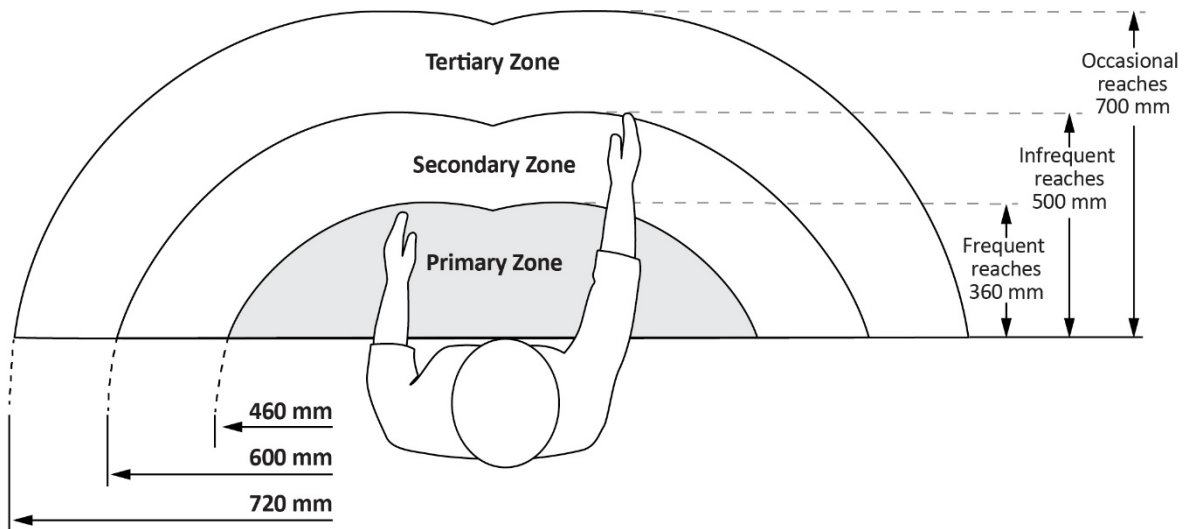

Figure 5-7. Recommended primary, secondary, and tertiary (outside the secondary) horizontal work zones.

5.15 User clearances under the work surface

5.15.1 Seated clearances

User clearance spaces under all working surfaces (i.e., primary work surface, display support surface, input-device support surface) shall

accommodate the upright seated posture and at least one of the other two seated reference working postures

Cable storage mechanisms or structural supports **shall not**

intrude into the clearance space beneath the work surface

The following dimensions define the required clearances for the intended users when seated. The limits of the height adjustability range at the forward edge of the work surface is based on thigh clearance. The limits of the height adjustability range at the level of the knee is based on height of the knee while seated. The width requirement is based on the width of the chair used.

Figure 5-8 illustrates a side view of the clearance space.

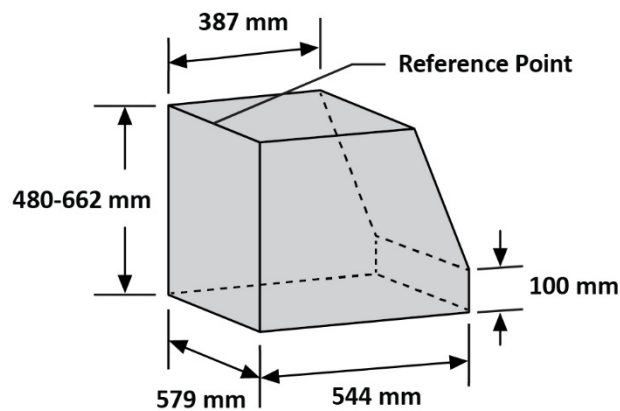

Figure 5-8 Illustration of a side view of the clearance space. The left side faces toward the user.

To provide sufficient clearance under the workspace for the legs and feet while seated, the clearance space **should**

be wide enough to allow the user to place their chair at least partially under the work surface

To accommodate at least 90 percent of the intended users, the clearance space for legs and feet under the surface **shall**

Standard anthropometric values:

be adjustable between 480 mm and 662 mm (18.9 in. and 26.1 in.) in height at the edge of the work surface closest to the user,

be at least 606 mm (23.9 in.) in height and 387 mm (15.25 in.) deep at the level of the knee, and

be at least 544 mm (21.4 in.) deep at foot level 100 mm (3.9 in.) above the floor. The 100-mm level is intended to allow clearance for the user's feet.

Applied values with allowance added:

Clearance space for legs and feet under the seated worksurface will be affected by the user's shoe. Adding the shoe allowance (30 mm, 1.2 in.), the clearance **shall**

be adjustable between 510 mm and 692 mm (20.1 in. and 27.2 in.) in height at the edge of the work surface closest to the user,

be at least 636 mm (25.0 in.) in height and 387 mm (15.25 in.) deep at the level of the knee, and

be at least 544 mm (21.4 in.) deep at foot level 130 mm (5.1 in.) above the floor. The 130-mm level is intended to allow clearance for the user's feet with shoes on.

The installed work surface **should not**

hinder the foot, leg, or knee in positions not included in the four reference postures.

5.15.2 Standing clearances

Clearance for users' feet under a standing work surface **should**

Standard anthropometric values:

be at least 100 mm (3.9 in.) in height, 510 mm (20.1 in.) in width, and 100 mm (3.9 in.) in depth

Applied values with allowance added:

Clearance for feet under a standing work surface will be affected by a user's shoe and movement.

Adding the allowances for shoe (30 mm, 1.2 in.) and movement (45 mm, 1.8 in.), the clearance **should**

be at least 130 mm (5.1 in.) in height, 555 mm (21.9 in.) in width, and 100 mm (3.9 in.) in depth

5.16 Electronic display support

The display support surface manufacturer **shall**

specify the size and weight of display that can be accommodated by the support surface and

specify the range of adjustment if the support surface is adjustable

The display support surface **should**

be designed to allow placement of the viewing area of the screen at a minimum viewing distance of 500 mm (19.7 in.)

be stable during use

not interfere with the user's ability to adjust the height, tilt, and rotation of the display

NOTE 1: Viewing distances are commonly greater than 500 mm and may range up to 1,000 mm.

NOTE 2: The maximum viewing distance is one that allows alphanumeric characters rendered on the screen (in their primary or default font) to subtend at least 16 arc minutes of visual angle; for example, 2.3 mm at 500 mm (0.1 in. at 19.7 in) viewing distance. This character size facilitates legibility; many individuals find that a character height of 20 to 22 arc minutes improves readability.

NOTE 3: The dimensions given in this standard reflect the minimally clothed dimensions. There are no standard allowances for clothing or movement used in this standard, as there are no generally agreed recommendations for clothing or movement allowances.

5.17 Input device support surfaces

Input device support surfaces may be designed for use while seated or standing. Input device support surfaces **shall**

comply with the clearance requirements specified in section 5.17, User clearances under the work surface

5.17.1 General specifications for sit, stand, or sit/stand input device support surfaces

If height- and tilt-adjustable, the input device support surface designed for both sitting and standing work postures **shall**

adjust in tilt in some portion of the range between -45 and +20 degrees, including 0 degrees, to facilitate user postures as described in Figure 5-1

The input device **should**

be placed within the recommended space for input devices.

The lateral boundaries of the input device space are swept out by the user's forearm-hand length when the included elbow angle varies between 70 and 135 degrees, as is shown in Figure 5-2. The shoulders are relaxed, the upper arm is approximately vertical, and the elbows are held loosely against the torso with no more than 20 degrees' abduction. For seated working positions, the lower limit of the elbow angle is determined by thigh clearance. A plan view of the recommended space is illustrated in Figure 5-9. The image

shows a right-handed individual. The placement of the input device could be switched to the other side for a left-handed user.

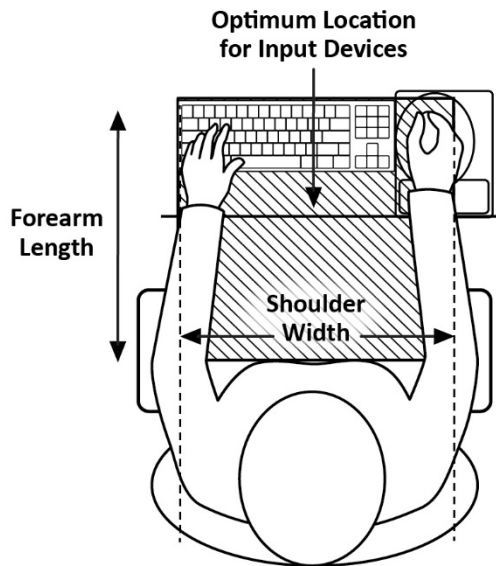

Figure 5-9. Plan view of the recommended space for placement for input devices.

If detachable, such as a keyboard tray, the input device support surface **should**

be marked to specify the range of adjustment for height and tilt

For sit/stand work, the input device support surface **shall**

accommodate at least one of the seated reference postures in addition to the standing reference posture without requiring the user to violate the user postural criteria described in 5.4.2, User postures

The manufacturer of an input device support surface **shall**

provide information regarding the range of height adjustment and

provide information regarding tilt adjustments

All detachable input device support surfaces (e.g., keyboard trays) **should**

adjust fore and aft in the horizontal plane,

adjust side-to-side within the recommended area for input devices, and

tilt

5.17.2 Sit-only working postures

If the input device support surface is tilt-adjustable, the tilt adjustment for sitting-only working postures **should**

provide tilt adjustment to include the range between –15 degrees and +20 degrees, including 0 degrees, in order to conform with the user postural guidelines specified in section 5.4.2

NOTE: Tilting the input device support surface more than 15 degrees below horizontal may interfere with clearance for the user's thighs.

The installed input device support surface designed for sitting-only working postures **shall**

Standard anthropometric values:

be adjustable in height by various means, such as manual, electric, or automatic and

have a surface height within the range of 554 mm to 739 mm (21.8 in. to 29.1 in.) as measured from the floor to the top of the surface

Applied values with allowance added:

Height of the sitting-only input device surface will be affected by the user's shoe. Adding the shoe allowance (30 mm, 1.2 in.), the input device height for sitting-only **shall**

be adjustable in height by various means, such as manual, electric, or automatic and

have a surface height within the range of 584 mm to 769 mm (23.0 in. to 30.3 in.) as measured from the floor to the top of the surface

5.17.3 Stand-only working postures

A non-tilting installed input device support surface designed for standing-only working postures **shall**

Standard anthropometric values:

have a surface height adjustment that includes at least the range of 914 mm to 1177 mm (36.0 in. to 46.3 in.) as measured from the floor to the top edge nearest the user

Applied values with allowance added:

Height of the standing-only input device surface will be affected by the user's shoe. Adding the shoe allowance (30 mm, 1.2 in.), the input device height for sitting-only **shall**

have a surface height adjustment that includes at least the range of 944 mm to 1207 mm (37.2 in. to 47.5 in.) as measured from the floor to the top edge nearest the user

If the input device support surface is tilt-adjustable, the tilt adjustment for standing-only working postures **should**

allow tilt adjustment that includes the range between –45 degrees and +20 degrees, to facilitate user postures as described in Figure 5-1

NOTE: The dimensions given in this standard reflect the minimally clothed dimensions. There are no standard allowances for clothing or movement used in this standard, as there are no generally agreed recommendations for clothing or movement allowances.

5.17.4 Sit/stand working postures

The installed input device support surface designed for both sitting and standing working postures **shall**

Standard anthropometric values:

adjust in height between 554 mm and 1,177 mm (21.8 in. and 46.3 in.) as measured from the floor to the surface at the top edge of the surface

Applied values with allowance added:

Height of the sit/stand input device surface will be affected by the user's shoe. Adding the shoe allowance (30 mm, 1.2 in.), the input device height for sitting-only **shall**

adjust in height between 584 mm and 1,207 mm (23.0 in. and 47.5 in.) as measured from the floor to the surface at the top edge of the surface

5.17.5 Stand-biased workstations

A stand-biased input device support surface is set at a fixed height to encourage standing while working. A seating device such as a tall chair (stool) or other device may be used to allow the user to support their weight while working and to alternate between standing and supported postures.

Any seating device used at a stand-biased workstation **shall**

have sufficient friction to prevent the chair from sliding on the floor during ingress or egress

When working at a stand-biased workstation, and to conform with section 5.4.2, User postures, the support **should**

provide knee clearance

A stand-biased workstation **shall**

Standard anthropometric values:

have a surface height within the range of 914 mm to 1177 mm (36.0 in. to 46.3 in.) as measured from the floor to the top edge nearest the user

Applied values with allowance added:

Height of the stand-biased input device surface will be affected by the user's shoe. Adding the shoe allowance (30 mm, 1.2 in.), the input device height for sitting-only **shall**

have a surface height within the range of 944 mm to 1207 mm (37.2 in. to 47.5 in.) as measured from the floor to the top edge nearest the user

A stand-biased workstation **should**

provide support to both feet while sitting, or to one foot while standing, with the other foot supported on the floor

The foot support **should**

Standard anthropometric values:

be at least 510 mm (20.1 in.) wide and 200 mm (7.9 in.) deep and

be height-adjustable up to 220 mm (8.7 in.) and may be adjustable in angle (pitch)

Applied values with allowance added:

Foot support for a stand-biased workstation will be affected by a user's shoe and movement. Adding the allowances for shoe (30 mm, 1.2 in.) and movement (45 mm, 1.8 in.), the foot support **should**

be at least 555 mm (21.9 in.) wide and 200 mm (7.9 in.) deep and

be height-adjustable up to 250 mm (9.8 in.) and may be adjustable in angle (pitch)

5.18 Display support device

Display support devices are used to support the computer display and allow the user to adjust the location of the display relative to their seated or standing position.

The display support device **shall**

allow users to adjust the line-of-sight (viewing) distance between their eye point and the surface of the viewable display area and

allow users to adjust the tilt and rotation angle between their eye point and the surface of the viewable display area

The display support device **should**

allow users to adjust the position of the display to the left or right of center, as necessary

The display support device **should**

allow users with normal visual capabilities to adjust the line-of-sight (viewing) distance between their eyes and the front (first) surface of the viewable display area within the range of 500 mm to 1,001 mm (19.7 in. to 39.4 in.)

The display support device **should**

be easily adjustable in all suggested directions without the use of tools and in a manner requiring minimal force by the user to create movement to another position

5.18.1 Display viewing angle

The center of the electronic display screen **should**

be located 15 degrees to 25 degrees below horizontal eye level

NOTE: Multifocal lens wearers often prefer angles low in the range specified or slightly lower.

During work periods, visual display screens **should not**

be located more than 35 degrees off to the side of the user's center line while the user is facing straight ahead

The entire visual area of a computer workstation, including items other than the display, such as the keyboard, **should**

be located between 0 degrees (horizontal eye height) and 60 degrees below eye height when users assume the upright sitting, reclined sitting, forward-tilting sitting, or standing reference postures

5.19 Seating

The furniture specifier or designer **should**

verify that the chair can be adjusted to provide clearance under the work surface and

provide information to the user as to the recommended use and adjustment of the chair

The chair **shall**

have a height-adjustable seat height,

allow the user to recline the backrest, and

allow adjustment of the amount of force required to recline to match the user's requirements

NOTE: User adjustment is defined as any method of adjusting the force required to recline. This can be accomplished either with manual devices (levers, knobs, adjustments, etc.) or automatically as users of different weights sit in the chair.

5.19.1 Seat height

The minimum range of seat height adjustment **shall**

Standard anthropometric values:

be adjustable by the user over a minimum range of 114 mm (4.5 in.) within the recommended range of 338 mm to 478 mm (13.3 in. to 18.8 in.)

Applied values with allowance added:

Seat height will be affected by a user's shoe. Adding the shoe allowance (30 mm, 1.2 in.), the seat height adjustment **shall**

be adjustable by the user over a minimum range of 114 mm (4.5 in.) within the recommended range of 368 mm to 508 mm (14.5 in. to 20.0 in.)

5.19.2 Seat pan depth and front edge

The seat pan **should**

have a waterfall or radiused front edge

The seat depth **shall**

Standard anthropometric values:

include a depth of 409 mm (16.1 in.) if adjustable

Applied values with allowance added:

Seat depth will be affected by clearance allowance to provide room for the back of the knee (popliteal area). Subtracting the clearance allowance, the seat depth **shall**

include a depth of 420 mm (16.5 in.) if adjustable

The seat depth **should**

Standard anthropometric values:

be no greater in depth than 409 mm (16.1 in.) if nonadjustable

Applied values with allowance added:

Seat depth will be affected by clearance allowance to provide room for the back of the knee (popliteal area). Subtracting the clearance allowance, the seat depth **shall**

be no greater in depth than 419 mm (16.5 in.) if nonadjustable

5.19.3 Seat pan width

The seat pan **shall**

Standard anthropometric values:

be at least 530 mm wide (20.9 in.)

Applied values with allowance added:

Seat pan width will be affected by the user's clothing. Adding clothing allowance (4 mm, 0.2 in.), the seat pan width **shall**

be at least 534 mm wide (21.0 in.)

NOTE: This seat width dimension is based on the 95th percentile value of females' seated hip breadth. It is important to note that a range of seat sizes and/or armrest adjustments may be necessary to accommodate smaller individuals.

5.19.4 Seat pan tilt angle

The seat pan tilt angle **should**

have a user-adjustable range of at least 4 degrees, which includes a reclined position of 3 degrees

NOTE: User adjustment is defined as any method of activating the movement of the seat pan/backrest. This can be accomplished either with manual devices (levers, knobs, adjustments, etc.) or by movement of the body.

5.19.5 Seat pan-backrest angle

If the backrest is adjustable, it **shall**

have an adjustment range of 15 degrees or more within the range ≥ 90 degrees and ≤ 120 degrees relative to the seat pan

If the backrest recline angle exceeds 120 degrees from the horizontal, the backrest **should**

have a headrest, preferably user-adjustable in height and depth

5.19.6 Backrest height and width

The backrest of the chair used to support the workstation user **shall not**

constrain the user's torso to a position forward of vertical and

allow adjustment of the angle between the backrest and seat pan to an angle of 90 degrees or less while seated

The width of the backrest **should**

be at least 360 mm (14.2 in.) in the lumbar zone

If lumbar support is fixed, the position of the center of the lumbar support area of the backrest **shall**

be between 150 mm and 250 mm (5.9 in. and 9.8 in.) above the compressed seat height. If lumbar support is adjustable, it **should**

include the range between 150 mm and 250 mm (5.9 in. and 9.8 in.) above the compressed seat height

5.19.7 Armrests

This standard does not require that chairs include armrests.

The clearance between fixed armrests **should**

Standard anthropometric values:

be at least 530 mm (20.9 in.) between the inside edges of the armrest uprights or armrest pads

Applied values with allowance added:

Clearance between fixed armrests will be affected by the user's clothing. Adding clothing allowance (4 mm, 0.2 in.), the armrest **should**

be at least 530 mm (20.9 in.) between the inside edges of the armrest uprights or armrest pads

Fixed-height armrests **should**

be between 192 mm and 290 mm (7.6 in. to 11.4 in.) above the compressed seat pan height

Adjustable armrests **should**

Standard anthropometric values:

adjust in height from 192 mm to 290 mm (7.6 in. to 11.4 in.) above the compressed seat pan height,

include a clearance width of 530 mm (20.9 in.) between the inside edges of the armrest uprights or armrest pads, and

be adjustable by the user (for example, pivot or otherwise move)

Applied values with allowance added:

Clearance between adjustable armrests will be affected by the user's clothing. Adding clothing allowance (4 mm, 0.2 in.), the armrest **should**

adjust in height from 192 mm to 290 mm (7.6 in. to 11.4 in.) above the compressed seat pan height,

include a clearance width of 534 mm (21.0 in.) between the inside edges of the armrest uprights or armrest pads, and

be adjustable by the user (for example, pivot or otherwise move)

Armrests **should**

provide sufficient clearance to allow the user to sit or stand without interference,

not cause the user to violate any of the postural guidelines specified in the user postures section,

be designed to distribute forces evenly over the contact area,

not create excessive pressure points,

not irritate or abrade the skin,

allow adjustment of the clearance width between the armrests,

be detachable from the chair if necessary to fit the workplace, and

not put the user at risk by suddenly shifting during ingress/egress when being used to support part of their body weight and stabilize the chair swivel and roll

5.19.8 Casters

Castors on the chair used to support the workstation user **should**

be appropriate for the type of flooring at the workstation

5.19.9 Seating dimensional measurements

Measurements of seating dimensions **shall**

use a standard chair measuring device (CMD) as referenced in the cited standards, either ISO 24496:2017, Office furniture – Office chairs – Methods for the determination of dimensions, or BIFMA CMD-1-2013 Universal Measurement Procedure for the Use of BIFMA Chair Measuring Device

5.20 Accessories

5.20.1 Document holders

Adjustable document holders allow users to read and/or transcribe hard-copy materials without assuming awkward postures (Bauer & Wittig, 1998). Placing the hard-copy materials at a distance and angle from the user similar to those used for the display minimizes changes in visual accommodation and vergence, thereby reducing visual effort.

Document holders **should**

allow placement of materials adjacent to the display and at approximately the same height, distance, and angle relative to the user's eyes as the display, and

be stable when loaded with the intended materials

5.20.2 Forearm supports

For tasks requiring prolonged use or precise control of input devices, supports **should**

be provided for the user's forearms and

facilitate user postures of the wrist and arm postural design criteria specified in section 5.4.2, User postures, of this document

The shape and firmness of the support **should**

be designed to distribute forces evenly over the contact area

5.20.3 Footrests

Footrests **shall**

be provided when the range of adjustment of the chair, work surface, or both does not permit the user's feet to be supported on the floor

To provide support for placement of feet, a footrest for seated work **should**

Standard anthropometric values:

be at least 510 mm (20.1 in.) wide and 200 mm (7.9 in.) deep and

be height-adjustable up to 220 mm (8.7 in.) and may be adjustable in angle (pitch)

Applied values with allowance added:

Footrests will be affected by a user's shoe and movement. Adding the allowances for shoe (30 mm,

1.2 in.) and movement (45 mm, 1.8 in.), the footrest **should**

be at least 555 mm (21.9 in.) wide and 200 mm (7.9 in.) deep and

be height-adjustable up to 250 mm (9.8 in.) and may be adjustable in angle (pitch)

5.21 Definitions and guidance of support devices for use with standing-height workstations

Given the general trend of providing alternatives to traditional seated work in a chair at a seated-height desk, it is important to identify various approaches to supporting body weight during use of a standing-height workstation. The following guidance is in order of increasing support of body weight during use of common standing-height workstations, including electric or other height-adjustable desks, stand-biased desks, and desktop units that rest on or attach to an existing seated desk. The use of many of these products also allows for use of cushioned mats for the feet. When used with mats, the mats should be integrated into the product in such a way that they do not place the user at risk of sliding or tripping during use and ingress/egress to the support item. Seat heights for standing support devices are intended to support a range of seated elbow heights while seated at a standing-height desk.

5.21.1 Lean support

A lean support is a type of support in which some of the body weight is supported by leaning the back (sacral through thoracic spine) against a contoured edge or vertical support that is rigid. Minimal body weight is supported by the lean support; the majority of the weight is on the feet, which are always on the floor. The user's posture is mostly standing.

Lean supports **should**

be constructed to resist tipping or sliding during use

They may accomplish this through counterbalance, rigid attachment to a false floor that uses body weight from the user, or other means of rigid attachment that prevents the user from falling backward during use.

The area of contact between the lean support and the users' backs may be rigid or flexible in tilt and or pivot and **should**

have a cushioned surface and contoured edges to minimize pressure points

Lean supports **should not**

swivel or roll during use but may roll into position prior to or after use

5.21.2 Prop

A prop is a type of seating support with a full seat, typically without armrests. During use the feet are always in contact with the floor and the seat may pivot and/or free float. Normally a prop is attached to a flat base

with which feet stay in contact during use. The user's posture is near standing.

Prop support seats may be rigid or pivot and or free-float under the seat or at the contact with the floor or its false floor. Prop supports **should**

be accomplished through contact friction with the floor or via support structures attached to a false floor

In either approach, prop supports **should not**

slide away from the user during use or ingress/egress and should be adjustable in height to accommodate small to tall standing buttock-thigh support

5.21.3 Perch

A perch is a type of seating support with a rigid, full seat and no backrest and which supports most of the user's weight on the seat but with some weight supported by the feet, which can be on the floor or on rings or rungs attached to the perch. The user's posture is seated but open, with a torso-to-thigh angle greater than 90 degrees.

Perch supports are traditional stools without backrests. They may be fixed height or adjustable in height. If adjustable in height, the seat surface **should**

Standard anthropometric values:

include part of the range of 610 mm to 914 mm (24.0 in. to 36.0 in.)

-

Applied values with allowance added:

Seat height will be affected by a user's shoe. Adding the shoe allowance (30 mm, 1.2 in.), the perch seat height adjustment **should**

include part of the range of 640 mm to 944 mm (25.2 in. to 37.2 in.)

-

They should provide rigid support and, if adjustable in angle of seat tilt, they **should**

be able to be locked at one position

They may have feet support in the form of rings or bars at 152 mm to 254 mm (6.0 in. to 10.0 in.) from the floor. These supports may be rigidly attached to a false floor or supported by various bases or legs that provide firm resistance to movement at the floor during ingress/egress, as these items do not typically include arms or backrests.

5.21.4 Stool

A stool is a tall chair with a full seat and backrest in which all the user's weight is supported by the stool. A stool may include arm rests, foot rings, or foot rails and various styles of bases. The user's posture is fully

seated.

Stools are tall chairs with a full seat and backrest that **should**

follow seating guidance provided in this document, and

provide foot rings, foot support platforms, or foot rails combined with casters and glides of various types designed to provide rolling resistance during ingress/egress

Stools may be incorporated into a false floor that moves with the stool. If adjustable in height, the stool seat height **should**

Standard anthropometric values:

provide height adjustability to include part of the range of heights from 584 mm to 914 mm (23.0 in. to 36.0 in.)

Applied values with allowance added:

Seat height will be affected by a user's shoe. Adding the shoe allowance (30 mm, 1.2 in.), the stool seat height adjustment **should**

include part of the range of 614 mm to 944 mm (24.2 in. to 37.2 in.)

If nonadjustable, the stool seat height **should**

Standard anthropometric values:

provide height adjustability to include part of the range of heights from 711 mm to 813 mm (28.0 in. to 32.0 in.)

Applied values with allowance added:

Seat height will be affected by a user's shoe. Adding the shoe allowance (30 mm, 1.2 in.), the stool seat height adjustment **should**

include part of the range of 741 mm to 843 mm (29.2 in. to 33.2 in.)

The stool **should**

meet or exceed ANSI/BIFMA 5.1 guidance related to tip resistance at its maximum seat height

References

- Bauer, W., & Wittig, T. (1998). Influence of screen and copy holder positions on head posture, muscle activity and user judgement. *Applied Ergonomics*, 29(3), 185–192.
- CAESAR Measurements (CD-ROM), North American Edition. SAE International.

- Chaffin, D. B., Andersson, G. B. J., & Martin, B. J. (1984). *Occupational ergonomics*. John Wiley & Sons.
- Cushman, W. H. (1984). Data entry performance and operator preferences for various keyboard heights. In E. Grandjean (Ed.), *Ergonomics and health in modern offices*. Taylor & Francis.
- Dainoff, M., Gordon, C., Robinette, K., & Strauss, M. (2003). *Guidelines for using anthropometric data in product design*. Human Factors and Ergonomics Society.
- Fryar, C. D., Gu, Q., Ogden, C. L., & Flegal, K. M. (2016). *Anthropometric reference data for children and adults: United States, 2011–2014* (Vital & Health Statistics Series 3, No. 39). U.S. Department of Health and Human Services. https://www.cdc.gov/nchs/data/series/sr_03/sr03_039.pdf
- Gordon, C. C., Corner, B. D., & Brantley, J. D. (1997). *Defining extreme sizes and shapes for body armor and load-bearing systems design: Multivariate analysis of U.S. Army torso dimensions* (No. NATICK/TR-97/012). Army Natick Research Development and Engineering Center.
- Grandjean, E., Hünting, W., & Pidermann, M. (1983). VDT workstation design: Preferred settings and their effects. *Human Factors*, 25, 161–175.
- Guan, J., Hsiao, H., Bradtmiller, B., Kau, T. Y., Reed, M. R., Jahns, S. K., et al. (2012). U.S. truck driver anthropometric study and multivariate anthropometric models for cab designs. *Human Factors*, 54, 849–871.
- Hedge, A., McCrobie, D., Morimoto, S., Land, B., & Rodriguez, S. (1995). *Beneficial effects of a preset tilt down keyboard system on posture and comfort in offices* (Report). Cornell University.
- Karlqvist, L. K., Hagberg, M., Köster, M., Wenemark, M., & Anell, R. (1996). Musculoskeletal symptoms among computer-assisted design (CAD) operators and evaluation of a self-assessment questionnaire. *International Journal of Occupational and Environmental Health*, 2(3), 185–194.
- Kreifeldt, J. G., & Nah, K. (1995). Adding and subtracting percentiles—How bad can it be? In *Proceedings of the Human Factors and Ergonomics Society 39th Annual Meeting* (pp. 301–305). Human Factors and Ergonomics Society.
- Kroemer, K. H. (1984). Engineering anthropometry. In H. Schmidke (Ed.), *Ergonomic data for equipment design* (pp. 101–114). Boston: Springer.
- Kroemer, K. H., Kroemer, H. B., & Kroemer-Elbert, K. E. (1994). *Ergonomics: How to design for ease and efficiency*. Prentice Hall.
- Miller, I., & Suther, T. W. (1981). Preferred height and angle settings of CRT and keyboard for a display station input task. In *Proceedings of the Human Factors Society 25th Annual Meeting* (pp. 492–496). Human Factors and Ergonomics Society.
- Rempel, D., & Horie, S. (1994). Effect of wrist posture during typing on carpal tunnel pressure. In *Proceedings of Working With Display Units: 4th International Scientific Conference*, Milan (p. C27).
- Rempel, D. M., Keir, P. J., & Bach, J. M. (2008). Effect of wrist posture on carpal tunnel pressure while typing. *Journal of Orthopaedic Research*, 26(9), 1269–1273.
- Robertson, M. M., Ciriello, V. M., & Garabet, A. M. (2013). Office ergonomics training and a sit-stand workstation: Effects on musculoskeletal and visual symptoms and performance of office workers. *Applied Ergonomics*, 44, 73–85.
- Robinette, K. M., Blackwell, S., Daanen, H., Boehmer, M., & Fleming, S. (2002). *Civilian American and European Surface Anthropometry Resource (CAESAR)* (Final Report, Vol. 1, Summary). Sytronics, Inc.
- Robinette, K. M., & McConville, J. T. (1981). *An alternative to percentile models* (SAE Tech. Paper 810217). SAE International.
- Sanders, M. S., & McCormick, E. J. (1993). Human factors in system design. In *Human factors in engineering*

and design (7th ed., pp. 726–745). McGraw-Hill.

Weber, A., Sancin, E., & Grandjean, E. (1984). The effects of various keyboard heights on EMG and physical discomfort. In E. Grandjean (Ed.), *Ergonomics and health in modern offices*. Taylor & Francis.

Ziolek, S. A., & Wawrow, P. (2004). *Beyond percentiles: An examination of occupant anthropometry and seat design* (SAE Tech. Paper No. 2004-01-0375). SAE International.